

Fitting instructions
Make: Citroën
C2; 2003->
Type: 3743

Permanently
linked to
quality

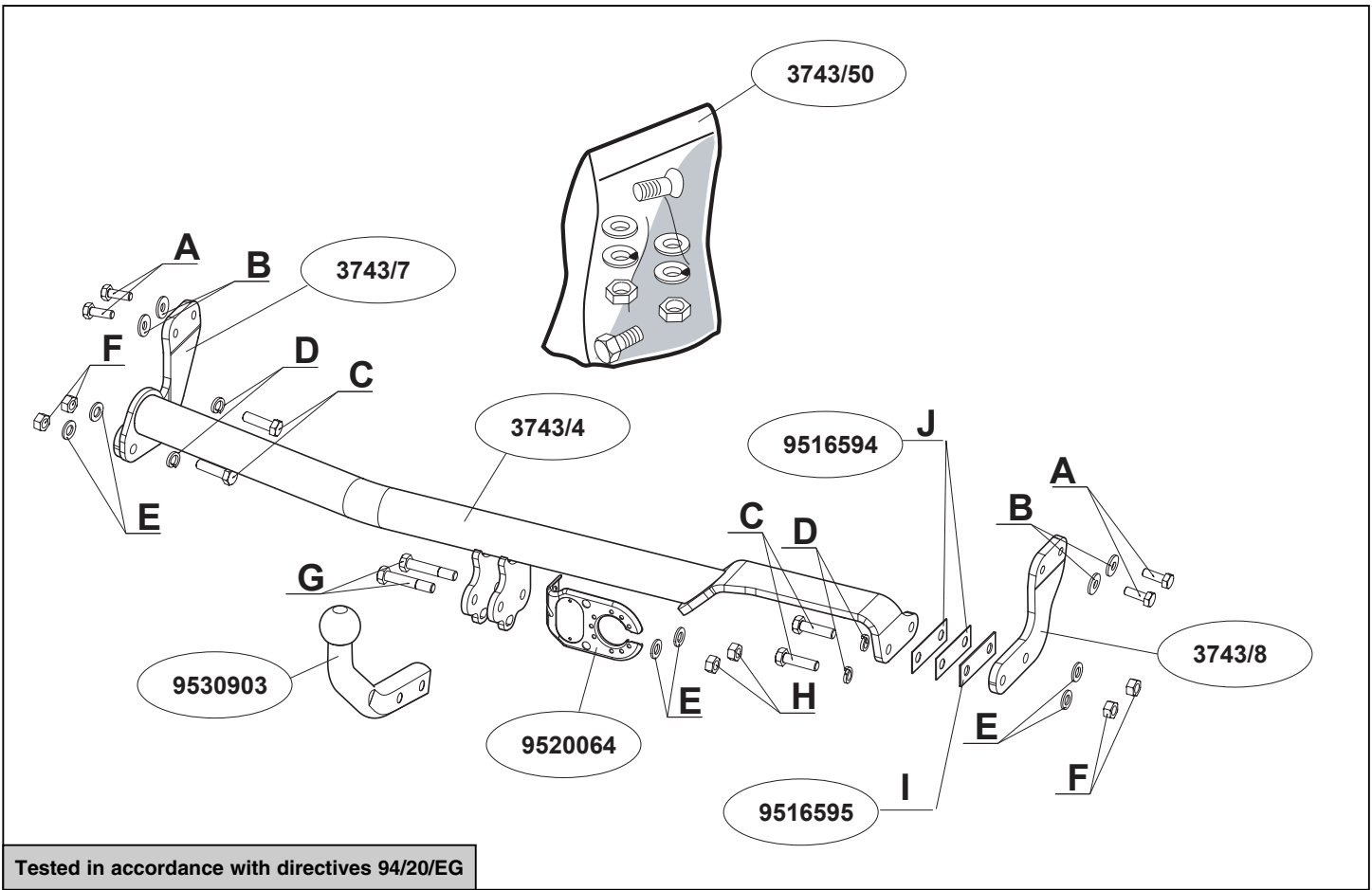

Tested in accordance with directives 94/20/EG

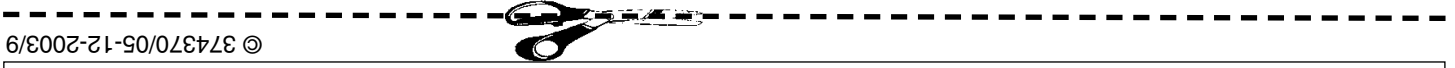
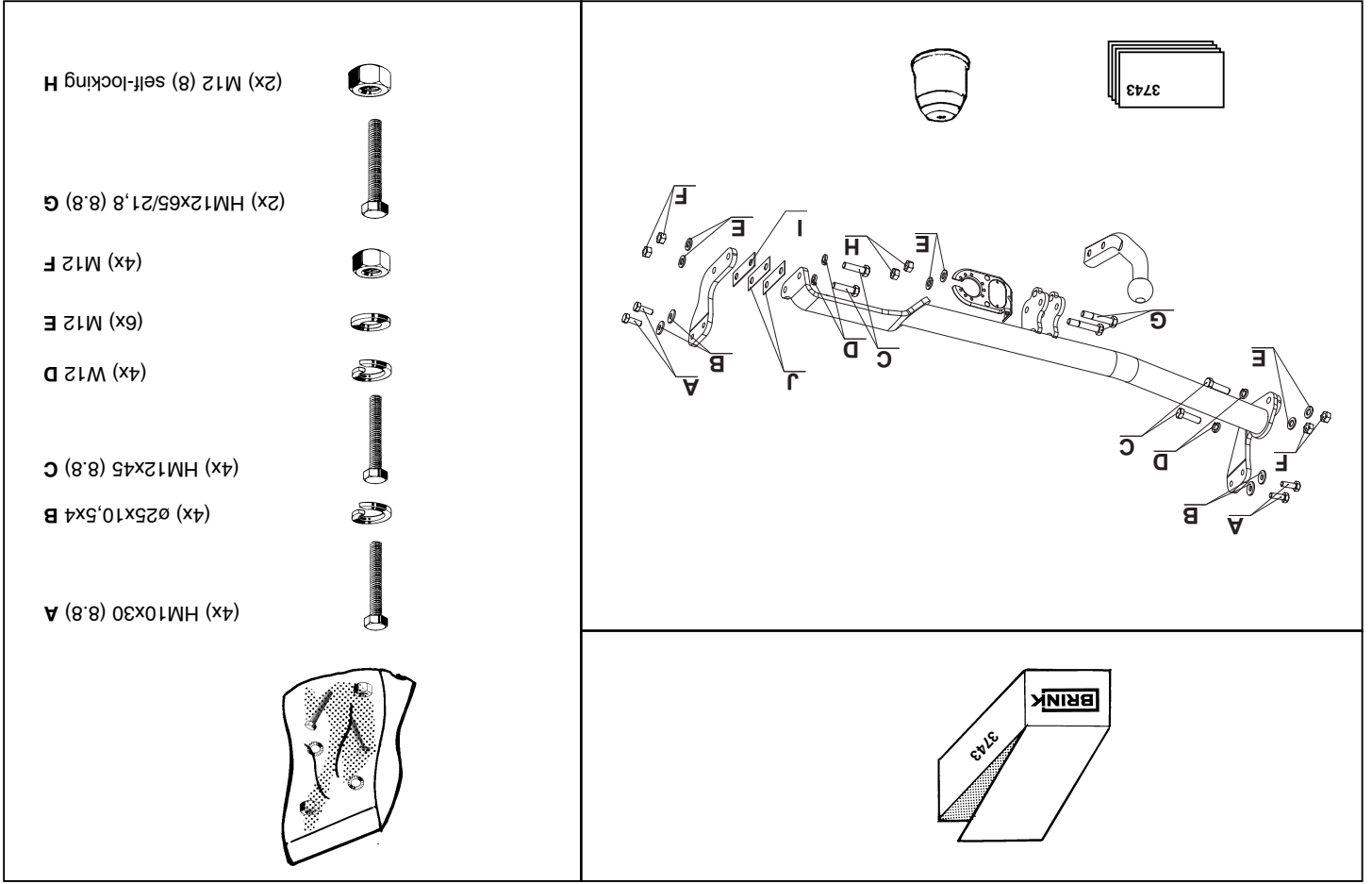

**DICHIARAZIONE DI CORRETTO MONTAGGIO:** la sottoscritta Ditta dichiara di aver montato in maniera corretta ed in conformità alle prescrizioni sia del costruttore del veicolo che del costruttore del dispositivo stesso il seguente dispositivo di attacco meccanico:

Il dispositivo di attacco sopra indicato è stato installato su autoveicolo

tipo:.....  
 modello:.....  
 targa:.....  
 Data:.....

Si dichiara inoltre di aver informato l'utente del veicolo sull'USO e MANUTENZIONE del dispositivo stesso.

**TIMBRO e FIRMA**

---

**DA COMPIRE PER IL COLLAUDO**

Per verificare l'idoneità del dispositivo di traino omologato a norma CEE 94/20, all'installazione sulla vettura su cui si intende procedere (declassare la massa rimorchiabile):

dove: T = Massa Complessiva Max. della motrice (in kg)  
 C = Massa Rimorchiabile Max. della motrice (in kg)

$$D = \frac{T + C}{T \times C} \times 0,00981 = \dots \text{KN} < D$$

Classe e tipo di attacco: A50-X  
 Omologazione: e11 00-4740  
 Valore D: 4,2 kN  
 Carico Verticale max. S: 27 kg  
 Larghezza rimorchiabile per Caravan e T.A.T.S.: 2,45m vedere CARTA di CIRCOLAZIONE VEICOLO (motrice) + 70 cm = ..arrotondare ai 5 cm  
 Massa rimorchiabile: vedi carta di circolazione dell' autoveicolo superiore (vedi D.M.28/05/85)

Dispositivo di traino tipo: Brink 3743  
 Citroën C2; 2003->  
 Tipo funzionale:

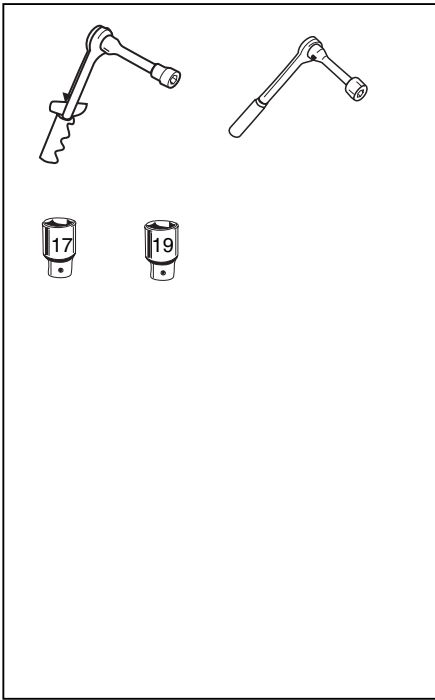

**D-value**

$$D = \frac{1300 \text{ K.G max} \times 600 \text{ K.G max}}{1300 \text{ K.G max} + 600 \text{ K.G max}} \times \frac{9.81}{1000} = 4.2 \text{ kN}$$

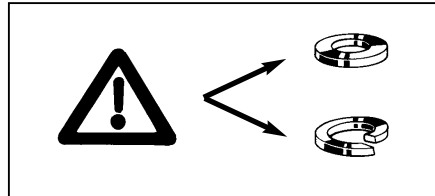
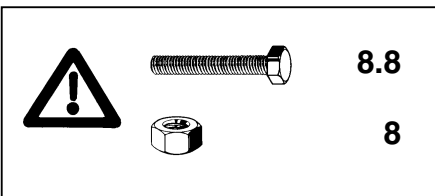
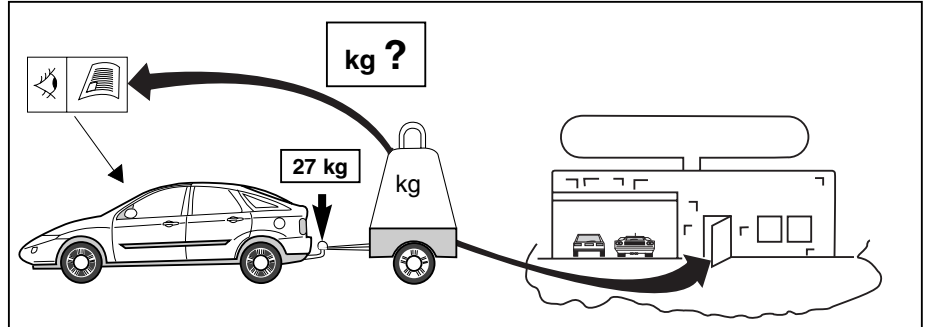

© 374370/05-12-2003/3

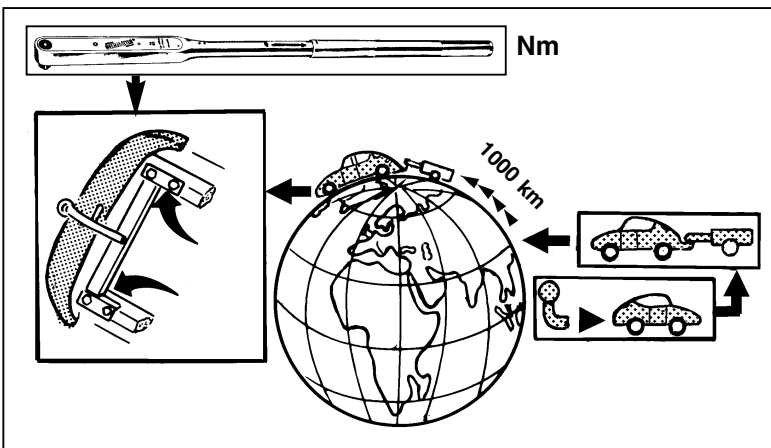

**HINWEISE:**

- \* Die für das Fahrzeug zugelassene Anhängelast ist den Fahrzeug Unterlagen zu entnehmen. Bei Änderungen des Fahrzeuggewichtes muß die höchstzulässige Anhängelast gegebenenfalls aus dem D-Wert nachgerechnet werden. Auskunft hierüber kann Ihr Fachhändler oder der TÜV geben.
- \* Elektrische Anlage gemäß StVZO anbringen.

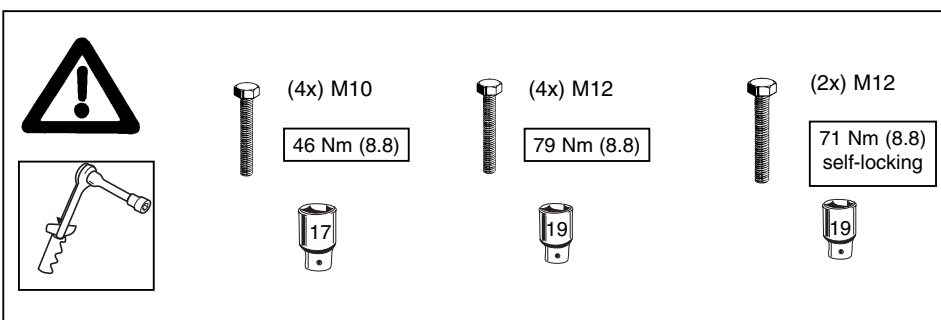

© 374370/05-12-2003/8

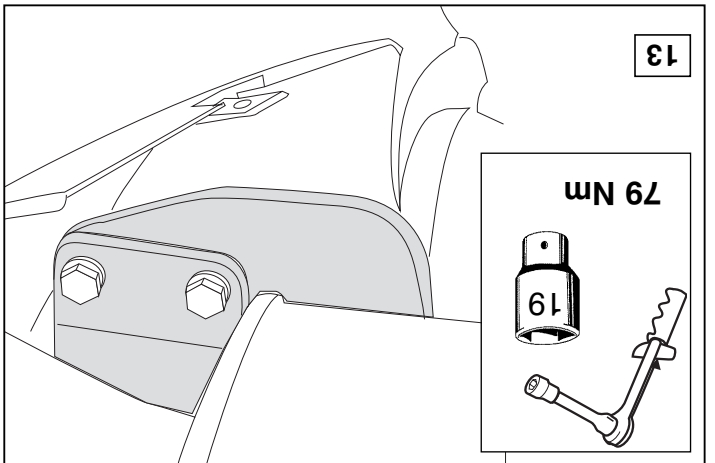
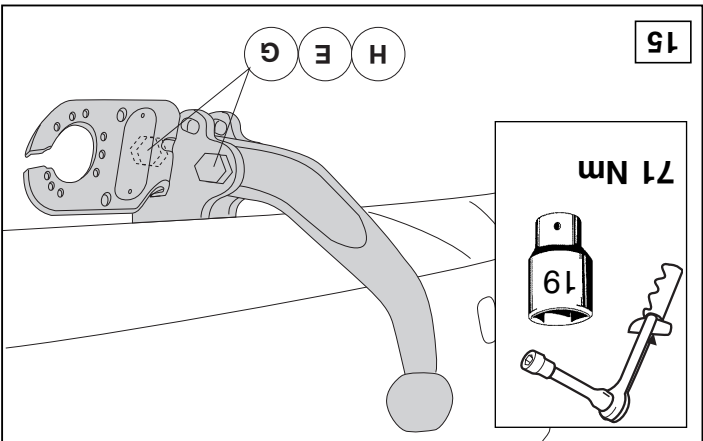
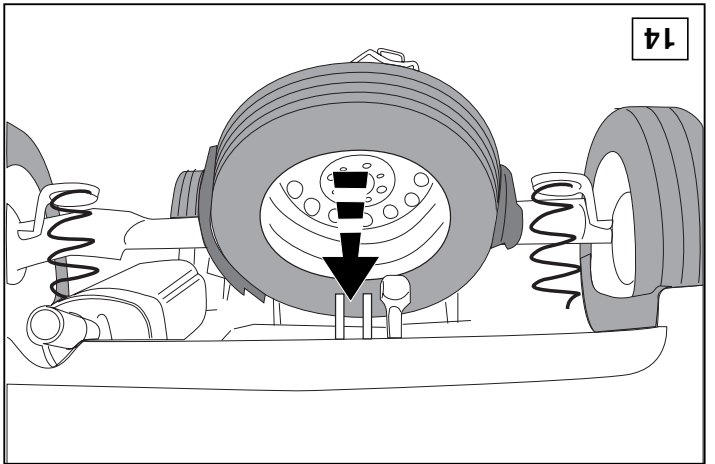
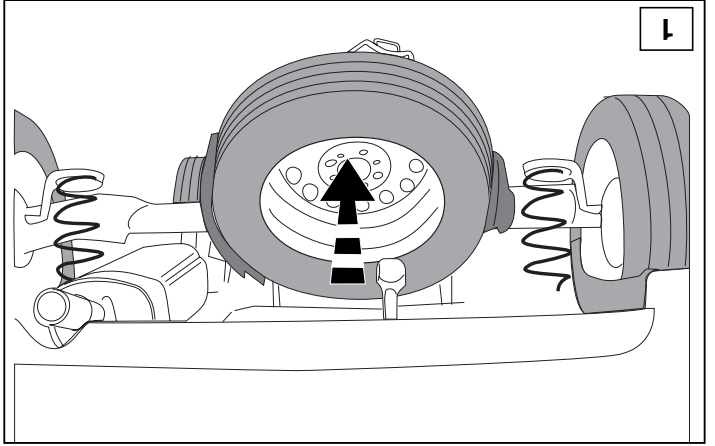
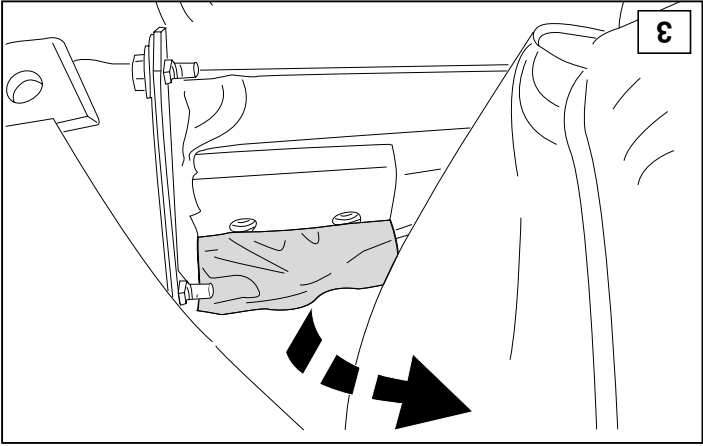
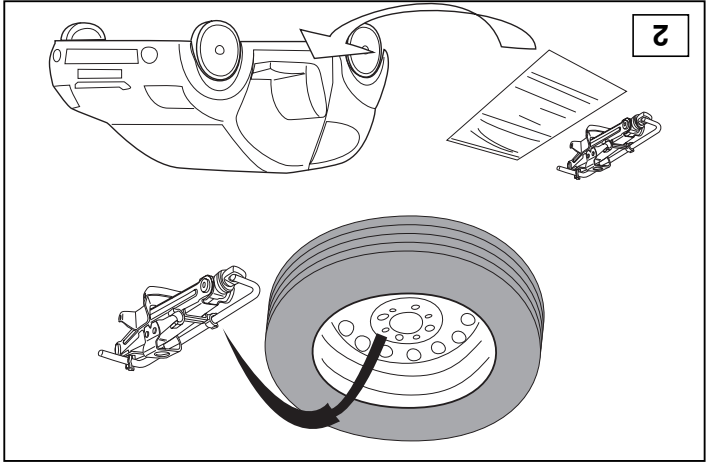
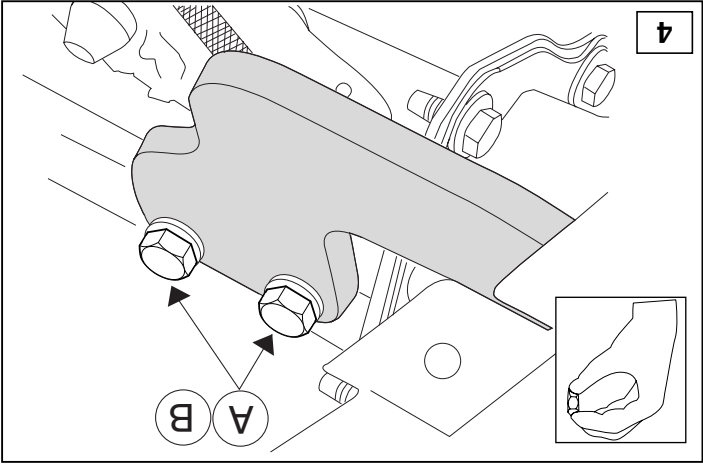

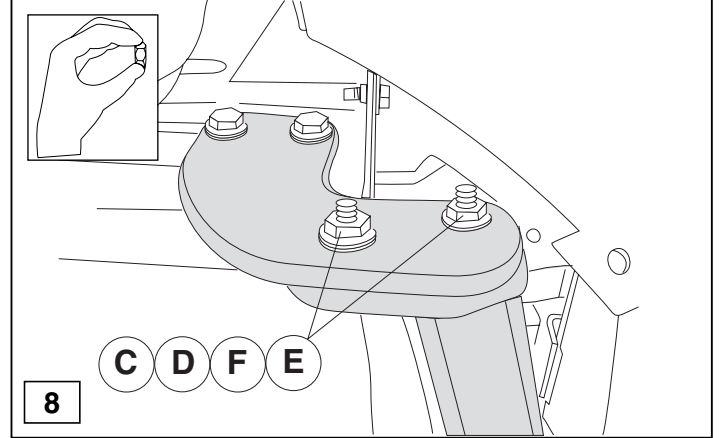
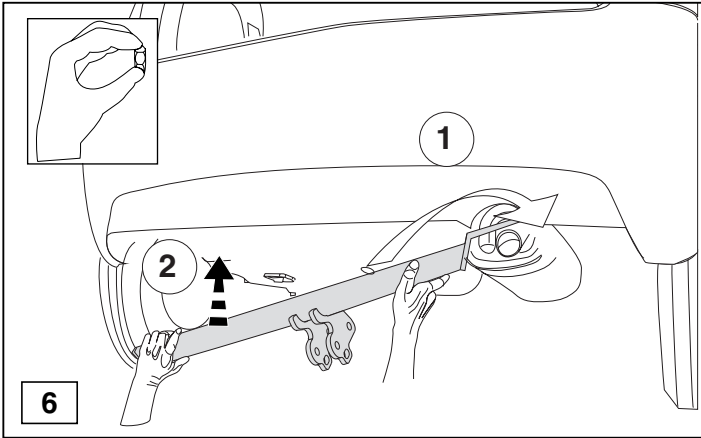
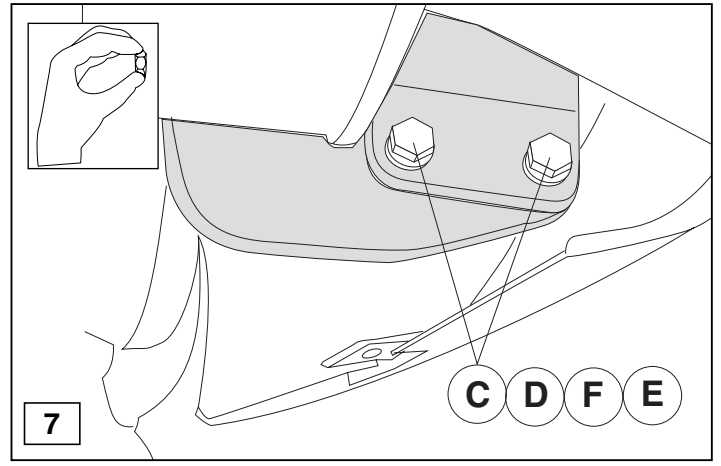
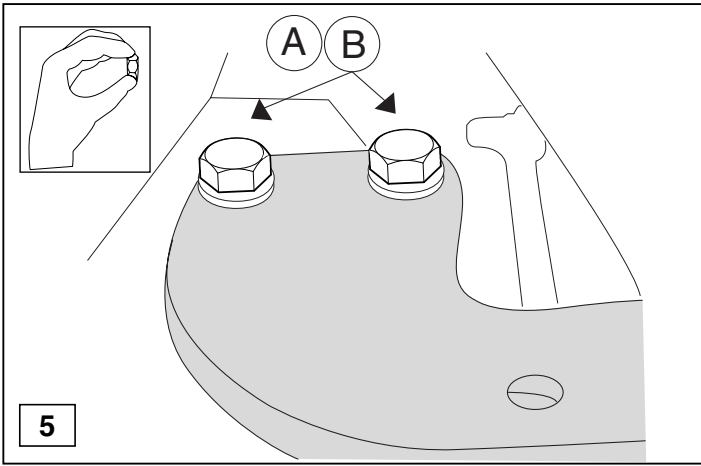

© 374370/05-12-2003/5

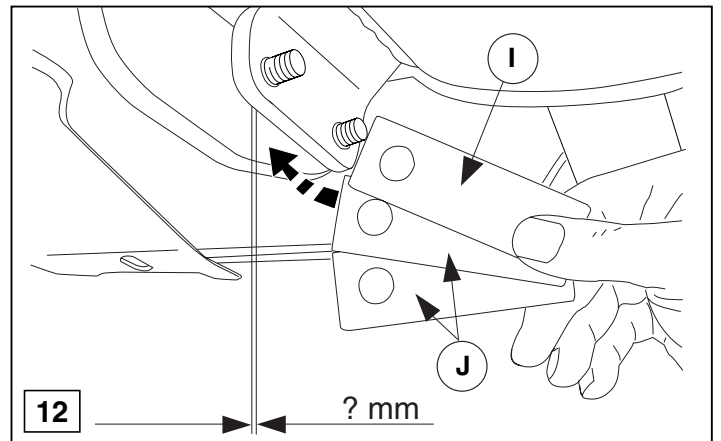
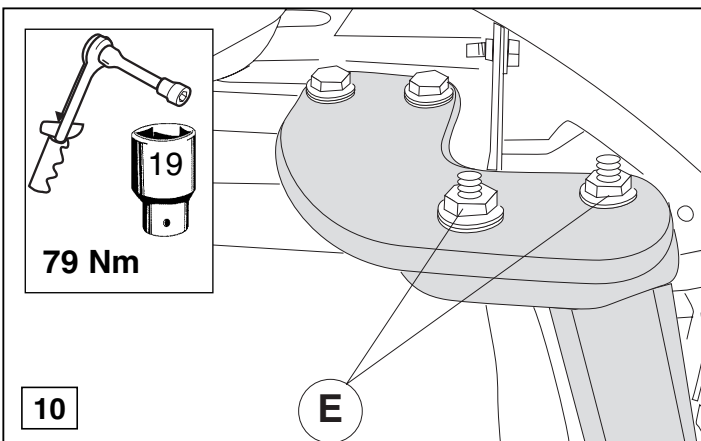
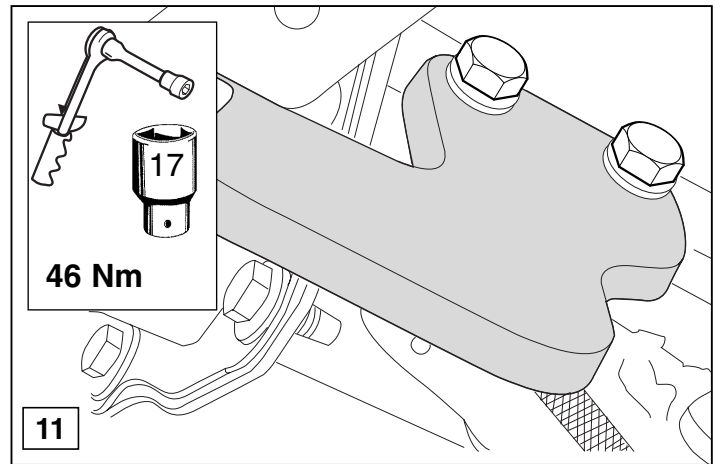
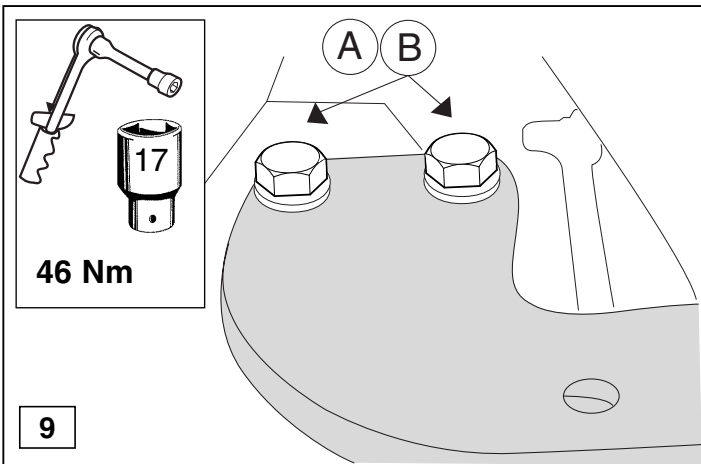

© 374370/05-12-2003/6