

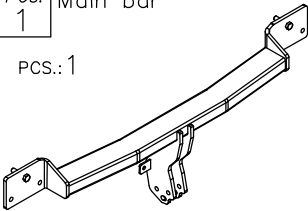

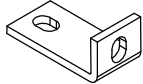

Towing hitch accessories:

Pos. 1 Main bar PCS.: 1	Pos. 6 Handle PCS.: 2	Pos. 13 Spring washer Ø12.2mm PCS.: 8
	Pos. 7 Angle bracket PCS.: 2	Pos. 14 Spring washer Ø10.2mm PCS.: 4
	Pos. 2 Tow ball PCS.: 1	Pos. 15 Bolt 8,8 B M8x45mm PCS.: 1
	Pos. 8 Bolt 8,8 B M12x70mm PCS.: 2	Pos. 16 Plain washer Ø8mm PCS.: 2
Pos. 3 Socket plate PCS.: 1	Pos. 9 Bolt 8,8 B M10x35mm PCS.: 4	Pos. 17 Nut 8 B M8 PCS.: 1
	Pos. 10 Nut 8 B M12 PCS.: 8	Pos. 18 Spring PCS.: 1
Pos. 4 Right bracket PCS.: 1	Pos. 11 Plain washer Ø13mm PCS.: 8	Pos. 19 Ball cover PCS.: 1
	Pos. 12 Plain washer Ø10.5mm PCS.: 4	
Pos. 5 Left bracket PCS.: 1		

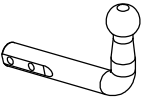

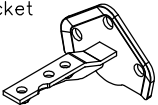
PPUH AUTO-HAK Sp.J.

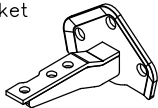
Produkcja Zaczepów Kulowych
Henryk i Zbigniew Nejman
76-200 SŁUPSK ul. Słoneczna 16K
tel/fax (059) 8-414-414; 8-414-413
E-mail: office@autohak.com.pl
www.autohak.com.pl

Towing hitch (without electrical set)

Class: **A50-X** Cat. no. **B08**

Designed for:

Manufacturer: **BMW**

Model: **SERIES 5 (E39)**

Type: **4 doors, except M Package/M5**

produced since 12.1995 till 2001

and since 2002 till 06.2003

Technical data:

D-value: 10,3 kN

maximum trailer weight: **2100 kg**

maximum vertical cup load: **90 kg**

Approval number acc. to regulations EKG/ONZ 55.01: E20-55R-01 1276

Foreword

This towing hitch is designed according to rules of safety traffic regulations. The towing hitch is a safety component and can be installed only by qualified personnel. Any alteration or conversion of the towing hitch is prohibited and would lead to cancellation of design certification. Remove insulating compound and underseal from vehicle (if present) in the area of the mating surfaces of the towing hitch.

The vehicle manufacturer's specifications regarding trailer load and max. vertical cup load are decisive for driving, and values for the towing hitch cannot be exceeded.

D-value formula:

$$\frac{\text{Max trailer weight [kg]} \times \text{Max vehicle weight [kg]}}{\text{Max trailer weight [kg]} + \text{Max vehicle weight [kg]}} \times \frac{9,81}{1000} = D \text{ [kN]}$$

FITTING INSTRUCTION

Clamp mark in acc. with		Cables joining
ISO	PN	
1	L	Left directional lights
2	+	Rear fog lights
3	31	Ground
4	R	Right directional lights
5	58R	Right side parking lights
6	54	Stoptlights
7	58L	Left side parking lights

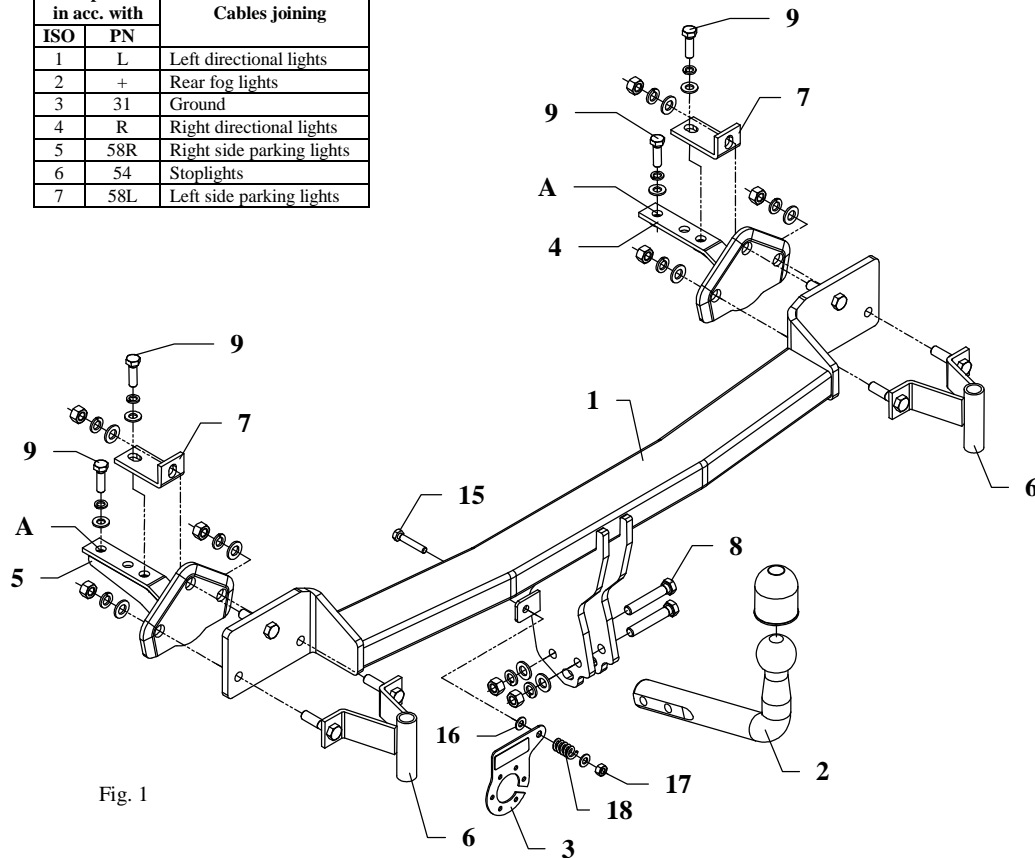

Fig. 1

The towing hitch is designed to fit in following car: **BMW 5 series E39, 4 doors, except M Package/M5** produced since 12.1995 till 2001 and produced since 2002 till 06.2003, catalogue no. **B08** and is prepared to tow trailers max trailers weight **2100 kg** and max vertical load **90 kg**.

From manufacturer

Thank you for buying our product. Their reliability has been confirmed in many tests. Reliability of towing hitch depends also on correct assembly and right operation. For this reasons we kindly ask to read carefully this instruction and apply to hints.

The towing hitch should be install in points described by a car producer.

The instruction of the assembly

1. Disassemble the bumper. Disassemble aluminium element and muffler from the bumper (this part will be not use any more).
2. In aluminium and plastic part of the bumper cut out fragments (as shown on the fig. 2 and 3).
3. In baggage part of the car disassemble covers (rear part and bottom).
4. Insert brackets (pos. 4 and 5) to chassis members (as shown on the fig. 1) and fix loosely through holes (pos. A) using bolts M10x35mm (pos. 9).
5. Fix handles (pos. 6) to the aluminium part of the bumper and next fix its plastic part.
6. So prepared towing hitch put to the rear part of car, put side brackets and angle bars (pos. 7) and fix.
7. Fix tow-ball (pos. 2) using bolts M12x70mm (pos. 8) from accessories.
8. Fix the socket plate (pos. 3) as shown on the drawing.
9. Tighten all bolts according to the torque shown in the table.
10. Connect electric wires of 7-poles socket according to the instruction of the car. (Recommend to make at authorized service station).
11. Complete paint layer damaged during installation.

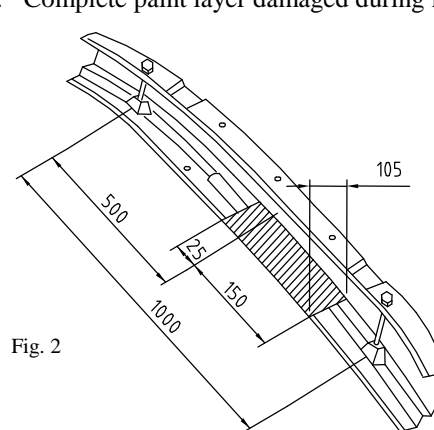

Fig. 2

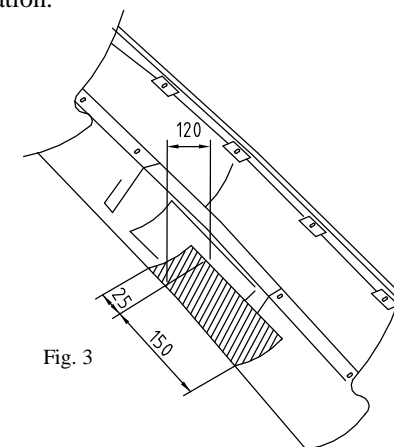

Fig. 3

Torque settings for nuts and bolts (8,8):

M6 - 11 Nm	M8 - 25 Nm	M10 - 50 Nm
M12 - 87 Nm	M14 - 138 Nm	M16 - 210 Nm

NOTE

After install the towing hitch you should get adequate note in registration book (at authorised service station).The car should be equipped with:

- Indicators
- Tow mirrors

After 1000km of exploitation check all bolts and nuts. The ball of towing hitch must be always kept clear and conserve with a grease.