

SEAT IBIZA 2008
SEAT IBIZA 2012
VW.POLO '09 -->
SEAT IBIZA ST 2010
AUDI A1 2010
SKODA FABIA 2015

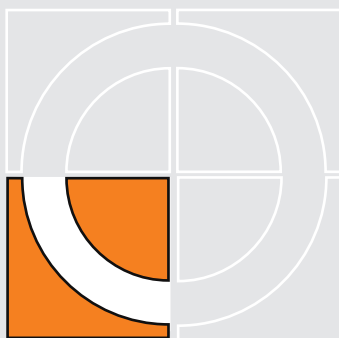
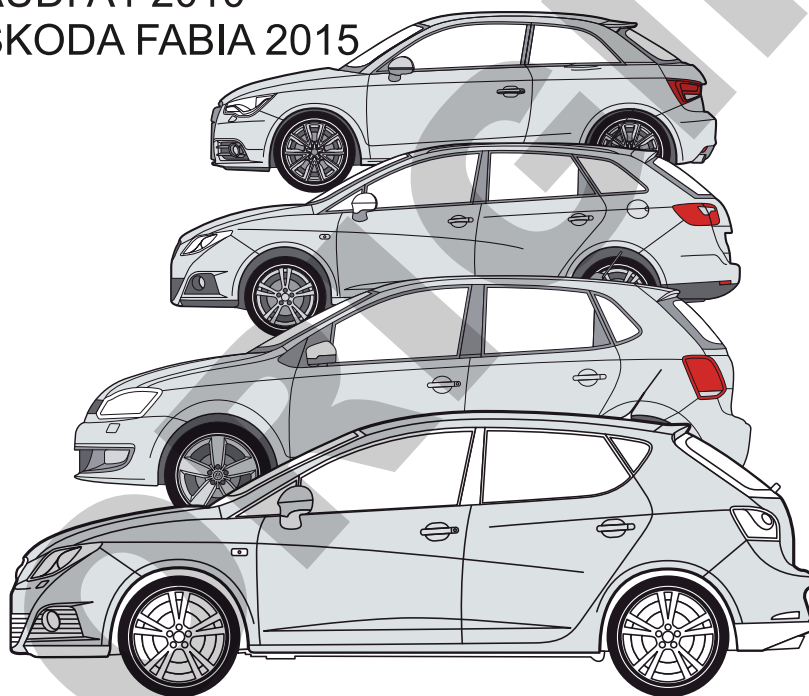

E

Enganches Aragón ofrece una garantía de sus productos por un período de dos años a partir de la fecha de entrega conforme a lo dispuesto en la Directiva 1999/44/CE y la ley 23/2003 quedando limitada al reemplazo de la mercancía defectuosa y en ningún caso se extenderá a daños o perjuicios consecuenciales.

Enganche fabricado por ENGANCHES ARAGÓN adaptable a la marca del vehículo.

Queda formalmente prohibido cualquier tipo de modificación, transformación o alteración sobre cualquiera de nuestros productos. El incumplimiento de esto daría lugar inmediatamente a la anulación de la homologación y de la garantía del producto.

Dependiendo de la versión y el año, una parte del paragolpes puede ser necesariamente recortada.

La información proporcionada por nosotros para el recorte del paragolpes es sólo una ayuda no vinculante.

El recorte se sabrá correctamente durante el montaje, con el tamaño requerido.

Es necesario sellar todos los puntos de anclaje del vehículo donde va sujeto el enganche para evitar la entrada de agua.

GB

Enganches Aragon offers a two years guarantee of their products from the delivery date according to arranged in the european directive 1999/44/CE and law 23/2003 being limited to the replacement of faulty products and in no case will be extended to damages or consequent harms.

Towbar made by ENGANCHES ARAGON adaptable to the brand of the vehicle.

It is forbidden to make any modification to our towbars. The breach of this condition will cancel the approval and the guarantee product.

Depending on car's version and year, part of the bumper need to be cut.

Information provided by us for the cutting of bumper is only a non binding help.

The cut will know properly during assembly with the required size.

It is necessary to seal all the anchor points of the vehicle where the tow bar is fixed to prevent entry of water.

F

Enganches Aragón offre une garantie de ses produits pour une période de deux années à partir de la date de livraison conformément à ce qu'est disposé dans la directive 1999/44/CE ainsi que la loi 23/2003 en étant limitée au remplacement de la marchandise défectueuse et dans aucun cas il sera étendu des dommages et intérêts.

Attelage fabriqué par ENGANCHES ARAGON adaptable à la marque de ce véhicule.

Il est interdit de faire des modifications ou transformations sur les attelages. Le Non respect de cela donnera lieu à l'immédiate annulation de l'homologation et de la garantie du produit.

Selon la version et l'année du véhicule, une partie du parechoc peut être découpée.

L'information transmise pour la découpe est seulement une aide, à chacun de vérifier la découpe nécessaire.

La découpe se verra correctement durant le montage, aux dimensions requises.

Il est nécessaire de joindre tous les points d'ancrage de l'attelage au véhicule afin d'empêcher toute entrée d'eau.

I

Enganches y remolques Enganches Aragon offre una garanzia dei suoi prodotti entro un periodo di due anni dalla data della consegna conforme alla direttiva 1999/44/CE e la legge 23/2003 che è limitata alla sostituzione della merce difettosa ed in nessun caso si estenderà ai danni o ai pregiudizi conseguenti.

Dispositivo di traino ENGANCHES ARAGON adeguato alla marca di questo veicolo.

È totalmente proibito effettuare qualsiasi tipo di modifica (fori'addizionali, saldare pezzi, togliere pezzi, ecc.) sui ganci. L'inadempienza di questa condizione provoca l'annullamento della garanzia e dell'omologazione del gancio.

Dipendendo dalla versione e dell'anno, un pezzo del paraurti può essere tagliato.

L'informazione proporzionata da noi per il paraurti è solo un aiuto non vincolante.

Il taglio si saprà esattamente durante il montaggio col formato necessario.

È necessario sigillare tutti i punti di fissaggio dove viene ancorato il gancio sul veicolo, onde evitare infiltrazioni

D

Enganches Aragon bietet eine garantie seiner Produkte gültig für 2 jahre ab dem Abgabedatum nach der europäischen Rechtlinie 1999/44/CE und dem Gesetz 23/2003 an. Die Garantie ist gültig für die Ersetzung der defekten Waren und auf keinen fall für die Schäden oder nachfolgenden Beschädigungen.

Für dieses Fahrzeug angepasst und hergestellt durch ENGANCHES ARAGON

Es ist strikt verboten, an den Kupplungen jegliche Veränderung (zusätzliche Löcher, Anschweißen von Teilen, Entfernung von Teilen) vorzunehmen. Die Nichteinhaltung dieser Bedingung hat die Ungültigkeit der Garantie und der Genehmigung der Kupplung zur Folge.

Je nach Ausstattungsvariante und Baujahr kann ein Ausschnitt des Stoßfängers zur Nachrüstung erforderlich sein.

Von uns gemachte Angaben zum Ausschnitt des Stoßfängers sind nur eine unverbindliche Hilfestellung.

Der Ausschnitt ist fachgerecht im Zuge der Montage auf die erforderliche Größe vorzunehmen.

Bitte versiegeln Sie alle Befestigungspunkte fachgerecht um ein Eindringen von Wasser zu verhindern.

NL

Enganches Aragon biedt een termijn van twee jaar garantie aan op haar producten vanaf de leveringsdatum overeenkomstig de afspraken in het Europese directief 1999/44/CE en wet 23/2003. De garantie beperkt zich specifiek tot het vervangen van foutief geleverde producten en zal in geen enkel geval uitgebreid worden bij schade of blijvend letsel.

Trekhaak welke geproduceerd zijn door ENGANCHES ARAGON zijn alleen te gebruiken voor het merk en type van het opgegeven voertuig.

Het is absoluut verboden om onze trekhaak, op welke manier dan ook, te modificeren. Indien aan deze conditie geen gevolg gegeven wordt vervalt de wettelijke type goedkeuring en daarmee de garantie op het product



Homologation
EC/94/20

SEAT IBIZA 2008
SEAT IBIZA 2012
VW.POLO '09
SEAT IBIZA ST 2010
AUDI A1 2010
SKODA FABIA 2015

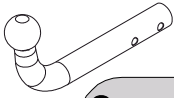

ENGANCHES ARAGON

CLASS: A 50-X
APPROVAL NUMBER
e 13 00-2823
TYPE: SET005
D-VALUE
D 7,73 kN
MAX. VERT. LOAD
S 75 kg
Tel: +34 976 45 71 30
www.enganchesaragon.com

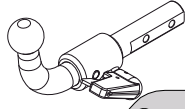

ENGANCHES ARAGON

CLASS: A 50-X
APPROVAL NUMBER
e 13 00-2824
TYPE: SET006-S
D-VALUE
D 7,73 kN
MAX. VERT. LOAD
S 75 kg
Tel: +34 976 45 71 30
www.enganchesaragon.com

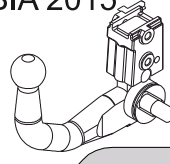

ENGANCHES ARAGON

CLASS: A 50-X
APPROVAL NUMBER
e 13 00-2824
TYPE: SET006-V
D-VALUE
D 7,73 kN
MAX. VERT. LOAD
S 75 kg
Tel: +34 976 45 71 30
www.enganchesaragon.com

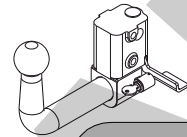

ENGANCHES ARAGON

CLASS: A 50-X
APPROVAL NUMBER
e 13 00-2824
TYPE: SET006-A
D-VALUE
D 7,73 kN
MAX. VERT. LOAD
S 75 kg
Tel: +34 976 45 71 30
www.enganchesaragon.com

T = 1450 kg

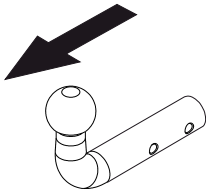

D = 7,73 kN

S = 75 kg

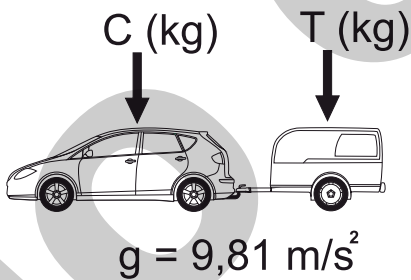
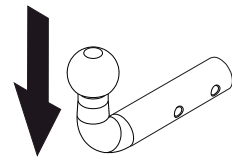

$$D \geq \frac{T \cdot C}{T+C} \cdot \frac{g}{1000} \text{ (kN)}$$



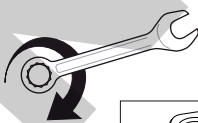





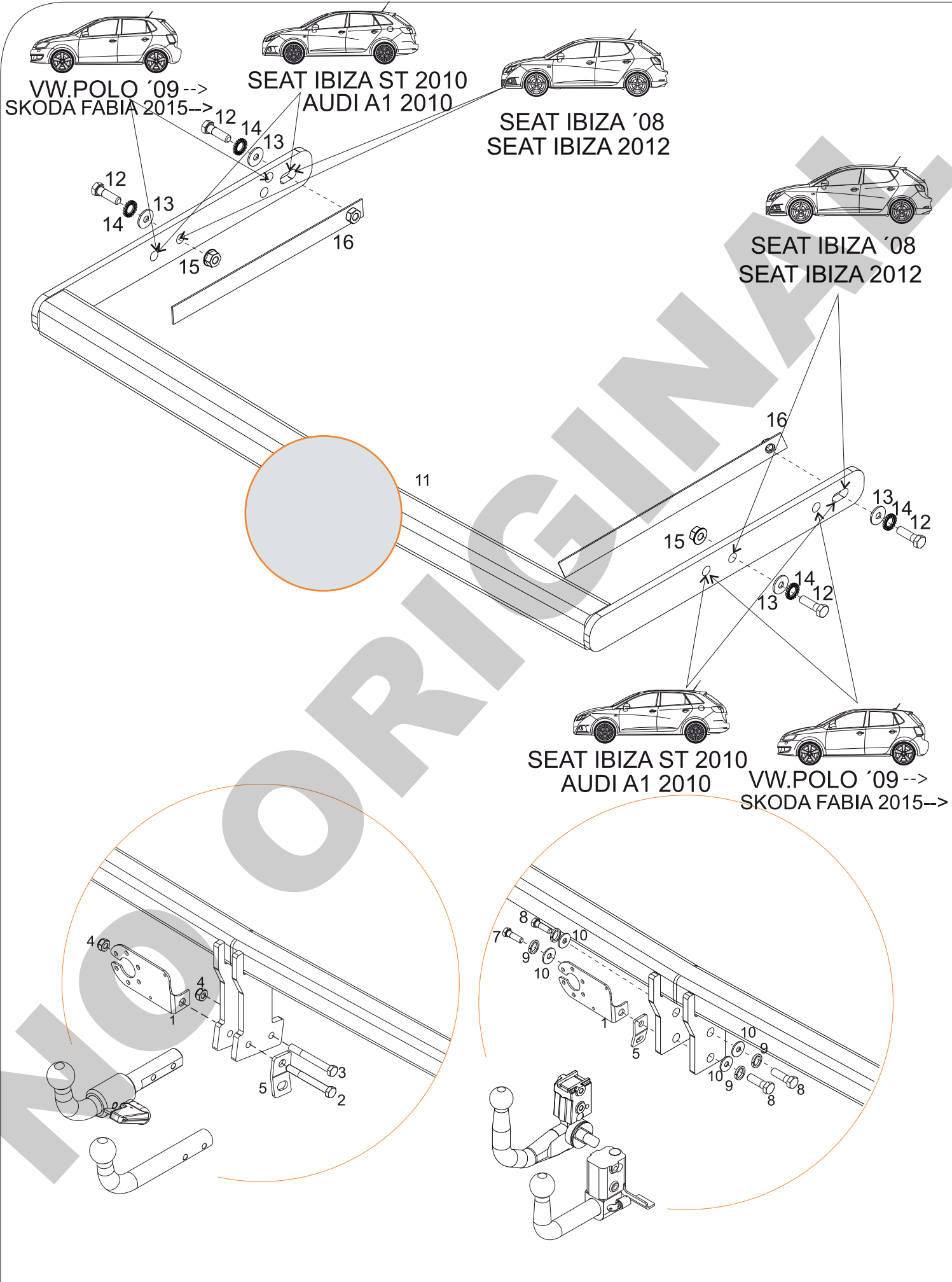

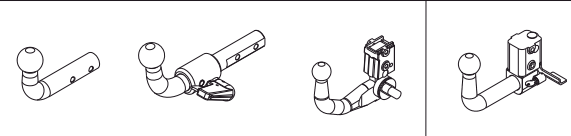





$$T \leq \frac{C \cdot D \cdot 1000}{(C \cdot g) - (1000 \cdot D)} \text{ (kg)}$$

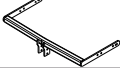

	M8	M10	M12	M14	M16
N/m	25	55	85	135	200





			
1			1
2		M10 x 70 DIN 931(8.8)	1
3		M10 x 65 DIN 931 (8.8)	1
4		M10 DIN 985	2
5			1
6			1
7		M12 x 35 DIN 933 (8.8)	1
8		M12 x 25 DIN 933 (8.8)	4
9		M12 DIN 128	4
10		M12 DIN 125	4
11			1
12		M10 x 35 DIN 933	4
13		M10 DIN 9021	4
14		M10 DIN 6789	4
15		M10 DIN 6923	2
16		CHAP A 320x25x2	2



1

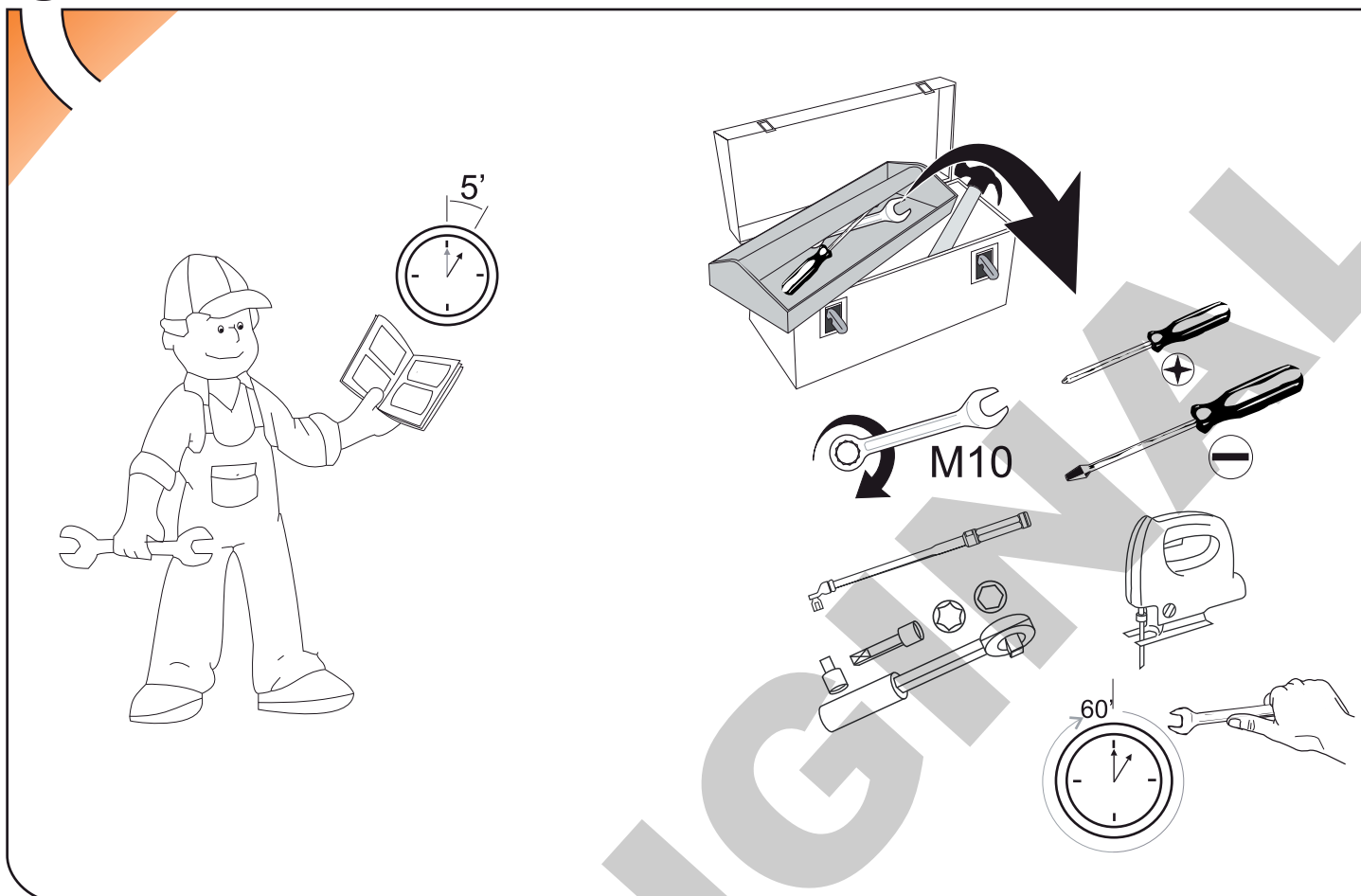

2

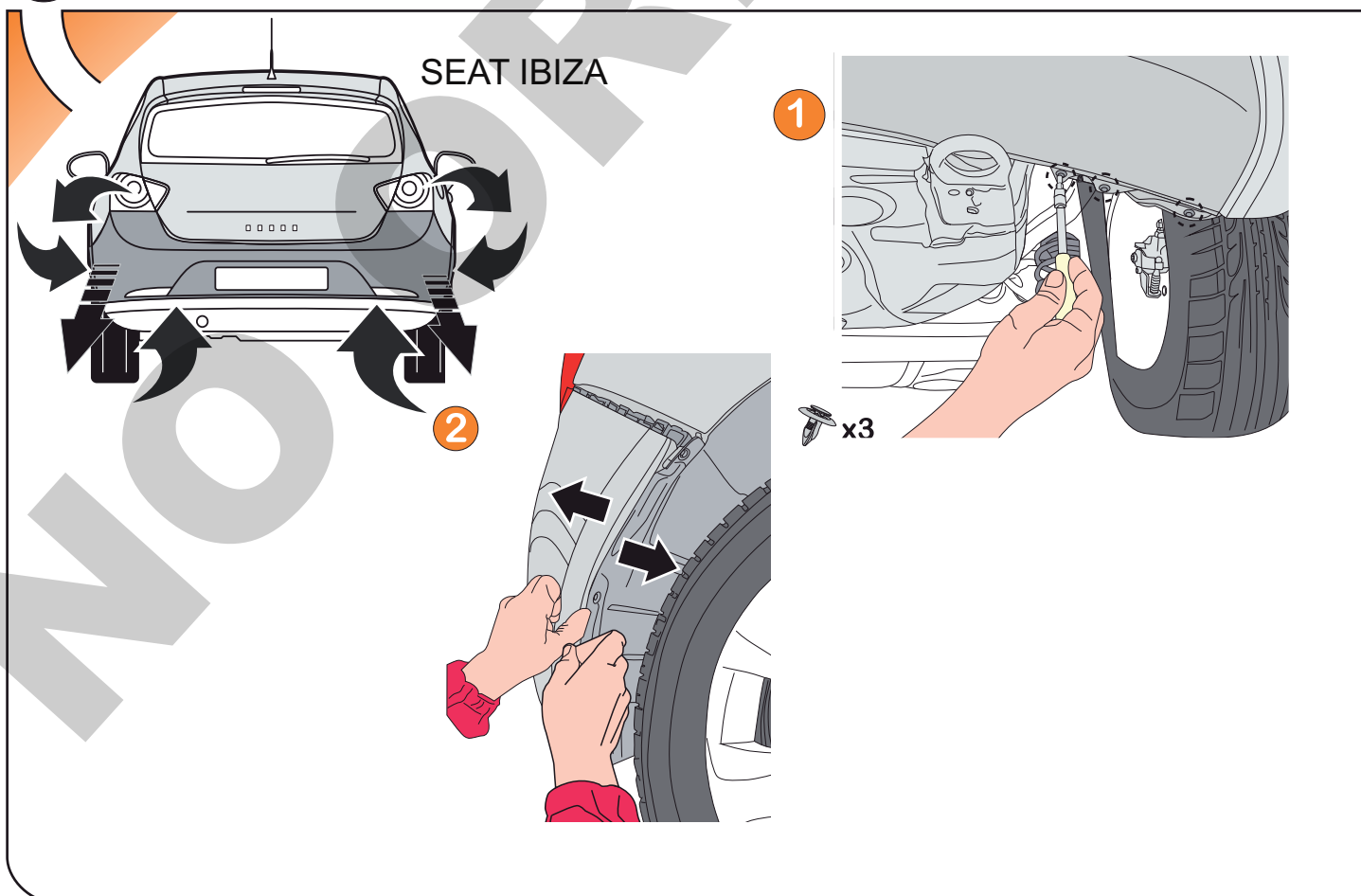

3

AUDI A1

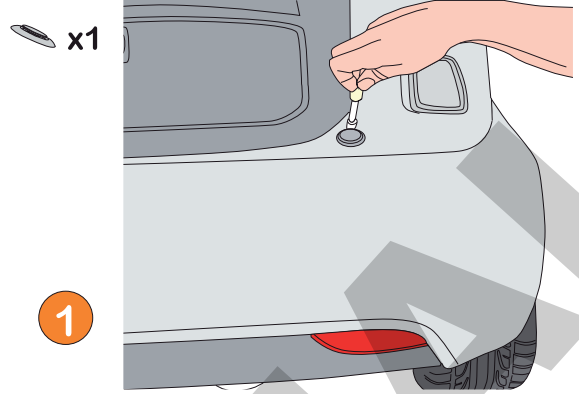

1

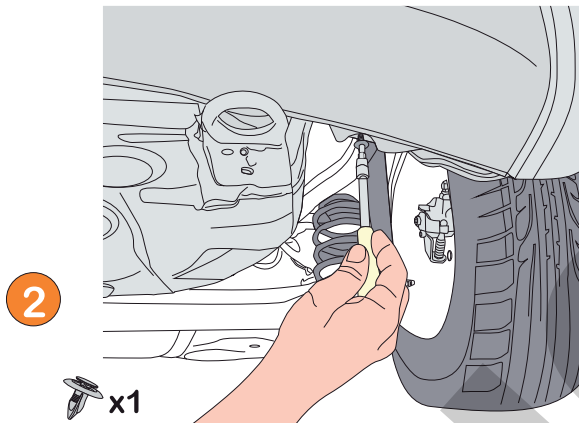

2

x1

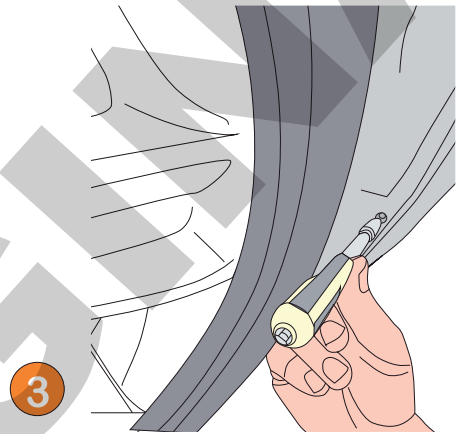

3

4

AUDI A1 2010

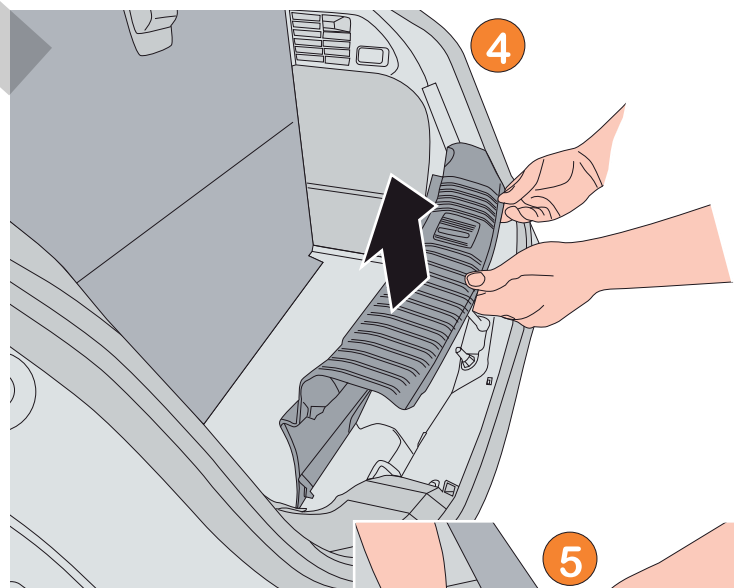

4

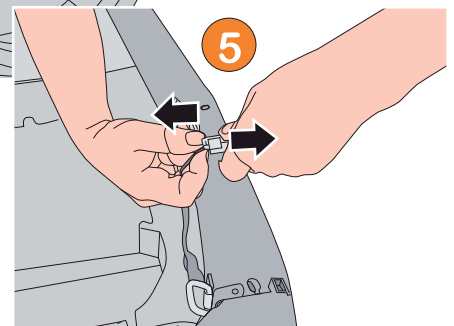

5

5

AUDI A1

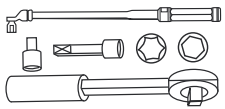
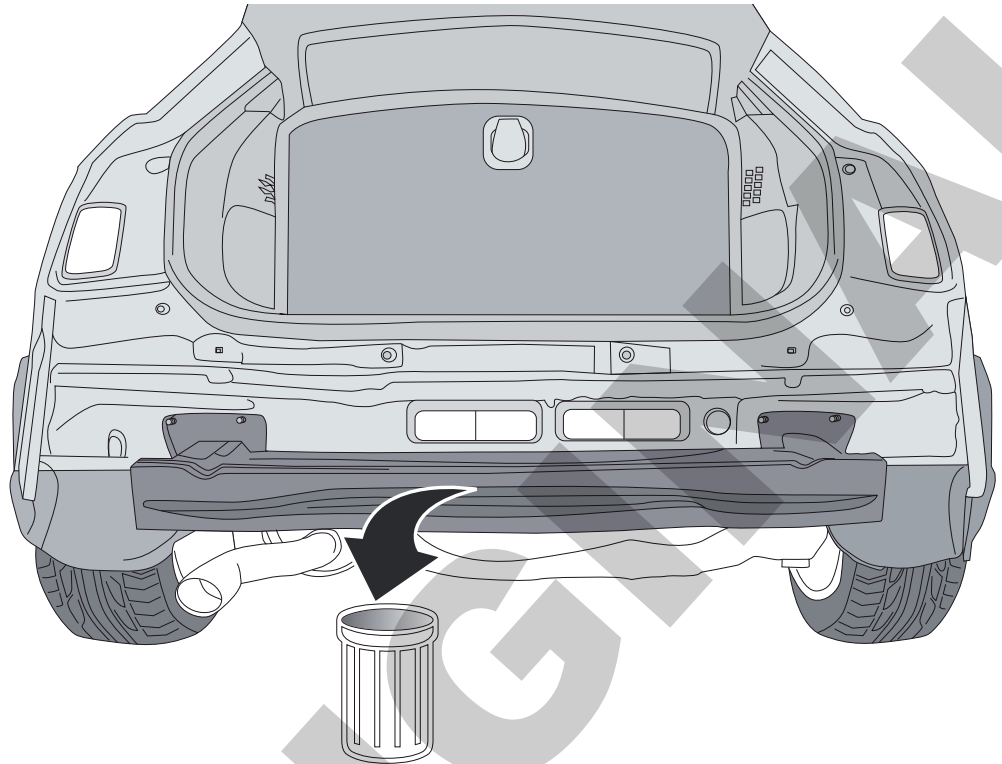
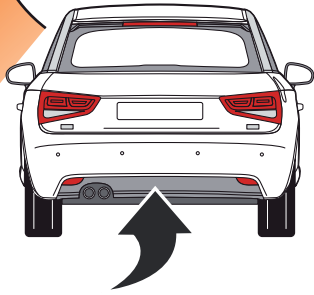

6

SEAT IBIZA

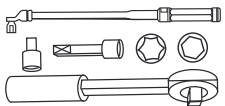
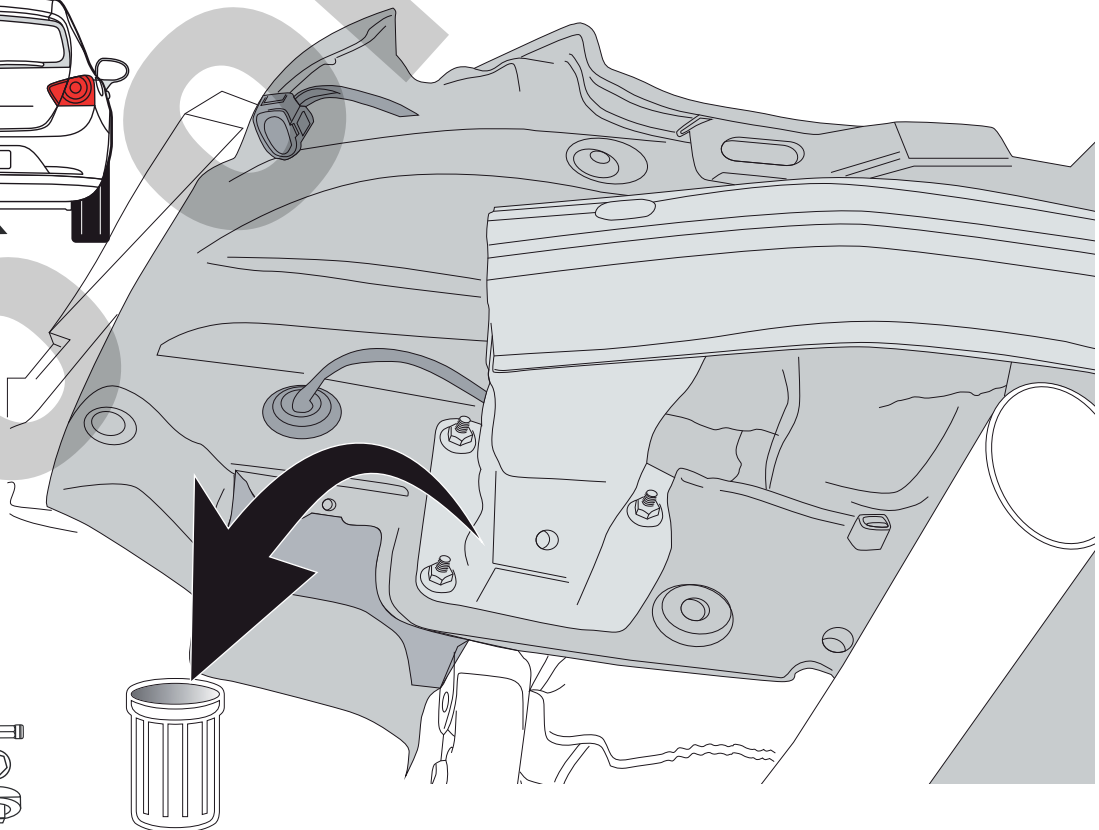
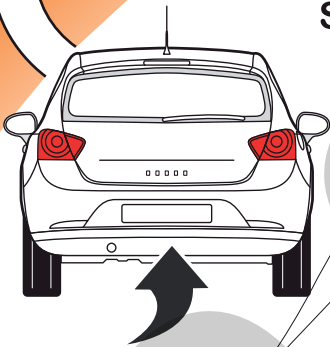

7

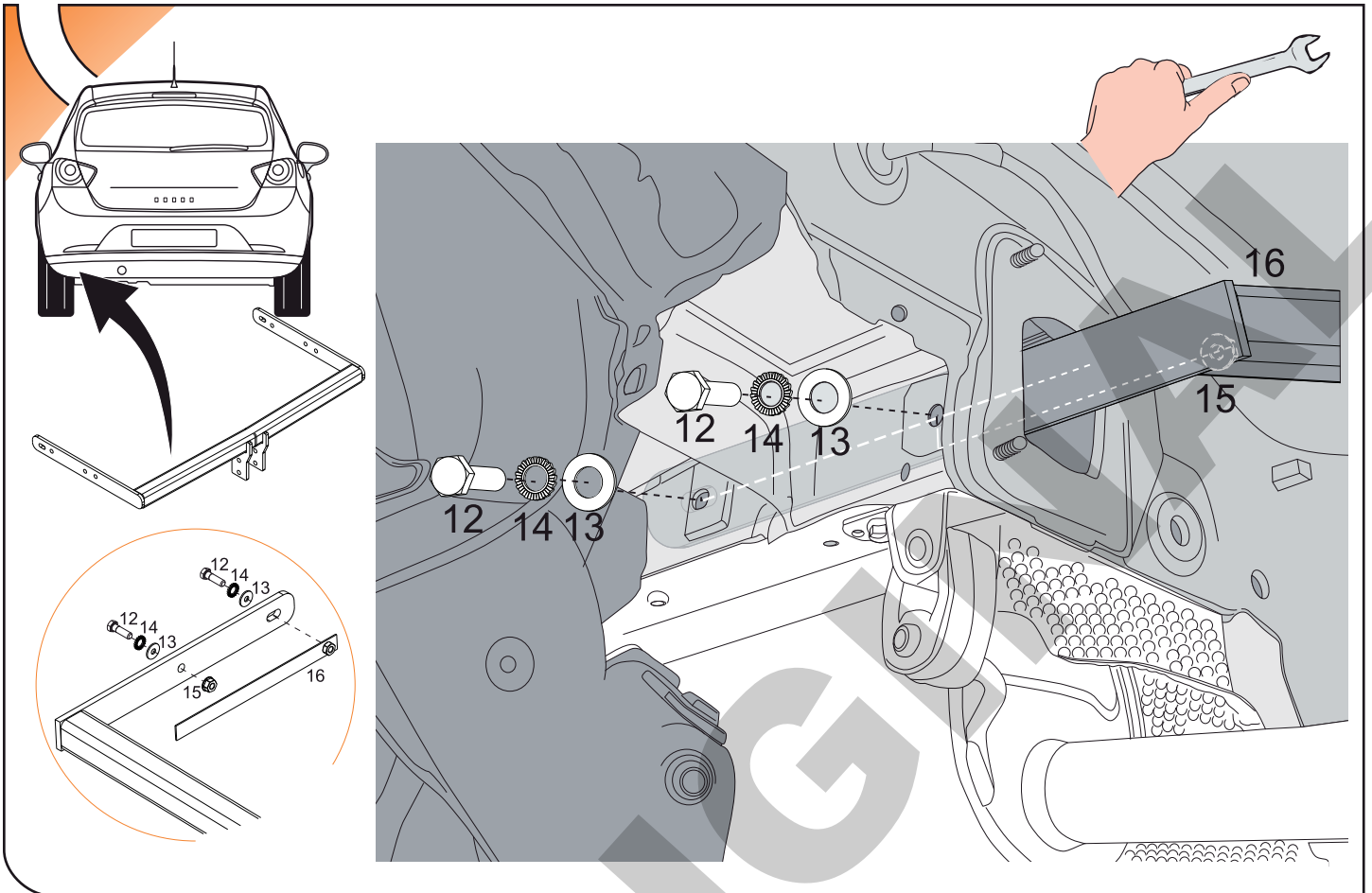

8

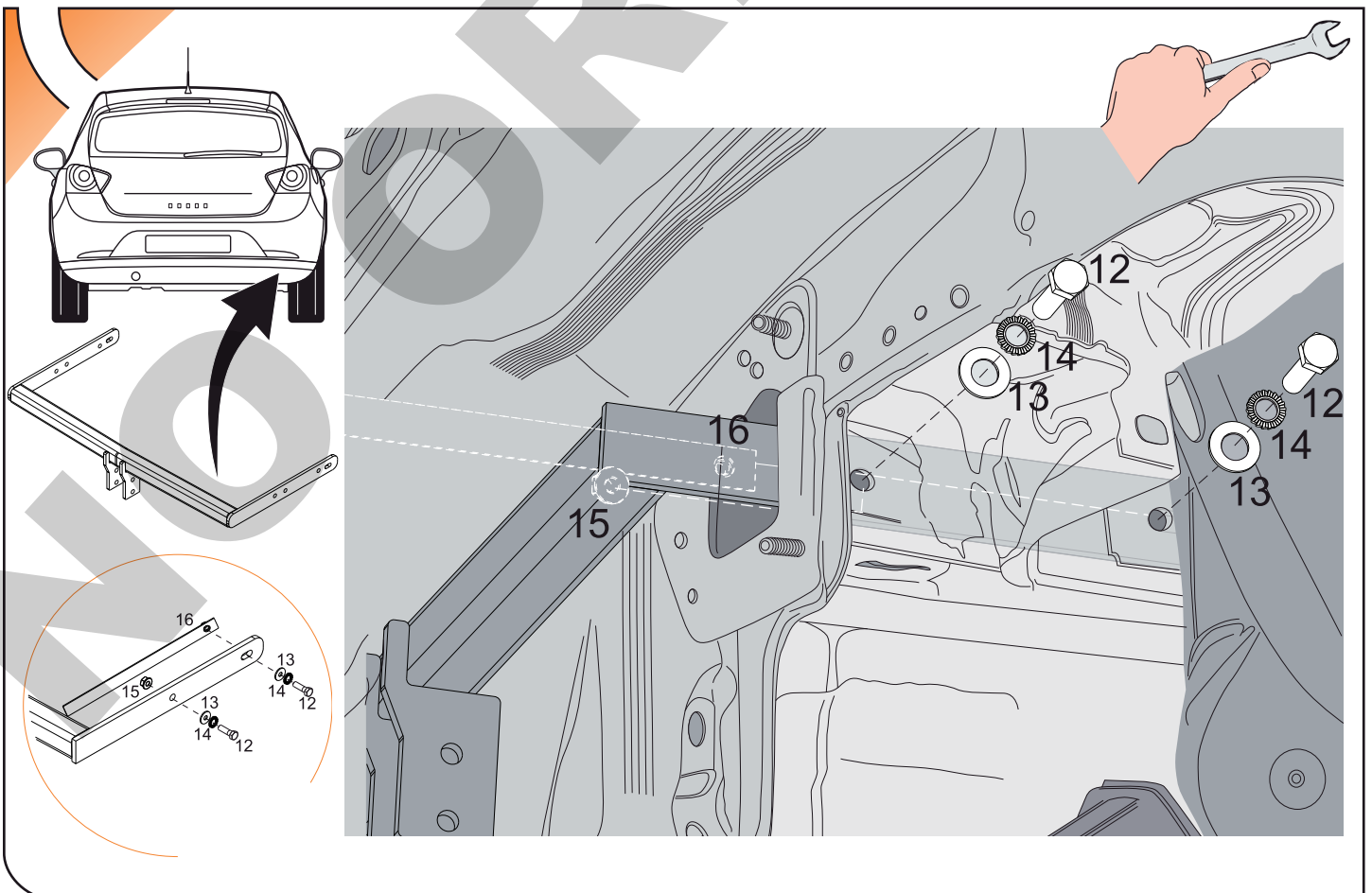

9

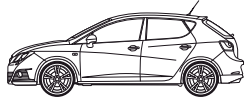
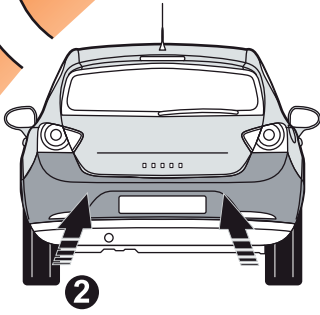

SEAT IBIZA '08
SEAT IBIZA 2012

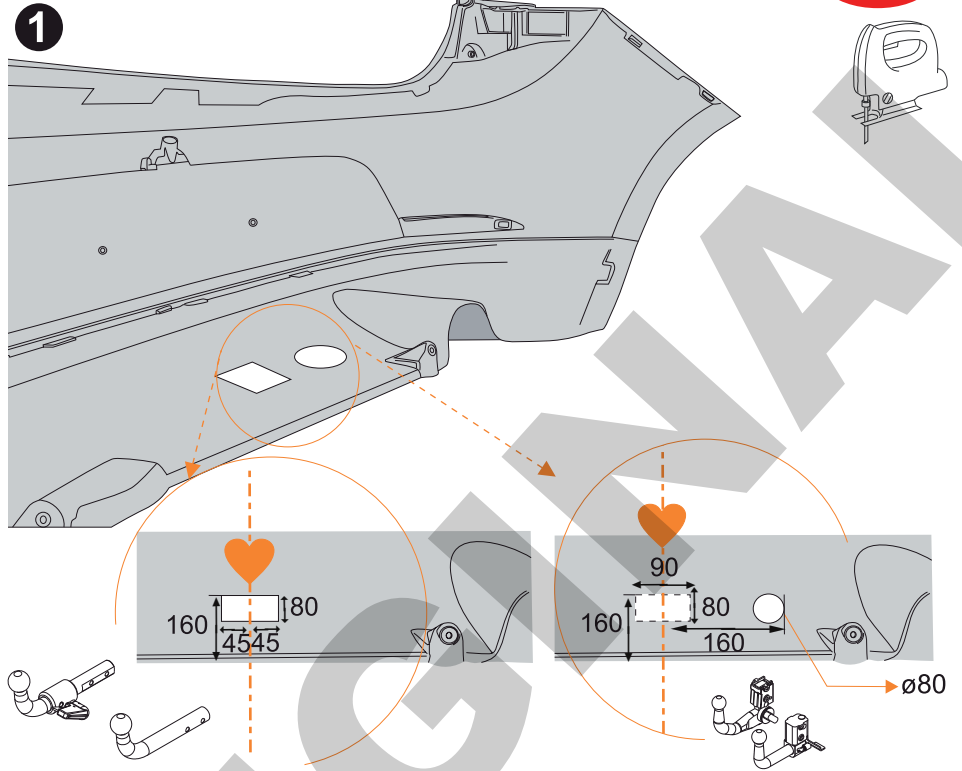

10



VW.POLO '09 -->

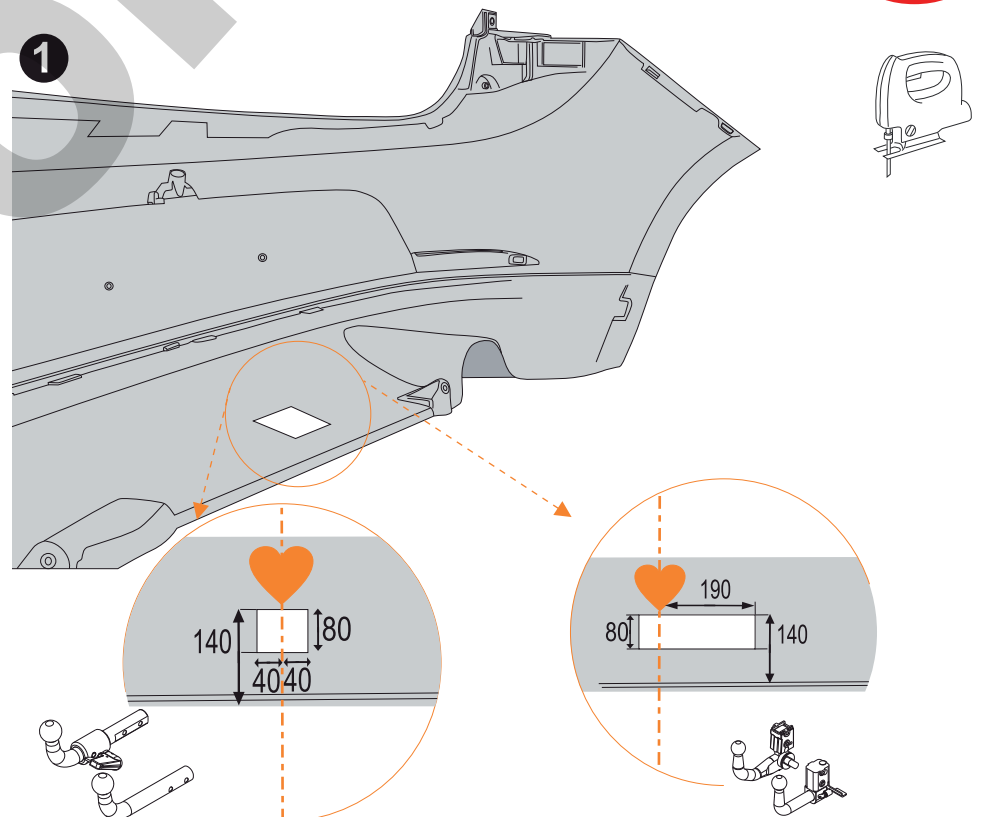

11



2



SEAT IBIZA ST

1

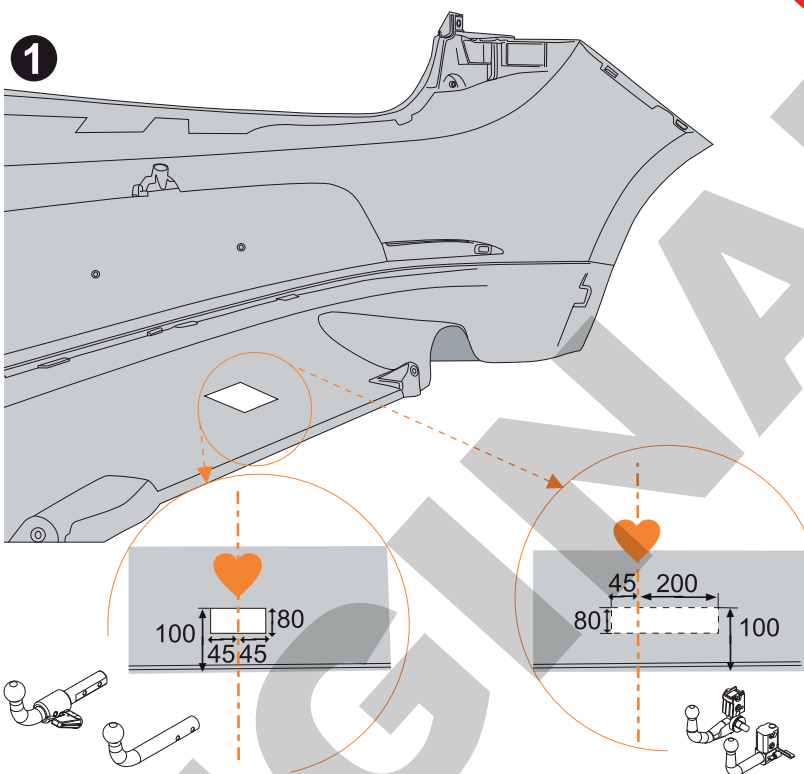

12



2

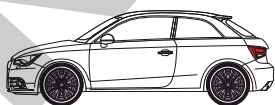

AUDI A1 2010
SKODA FABIA 2015-->

1

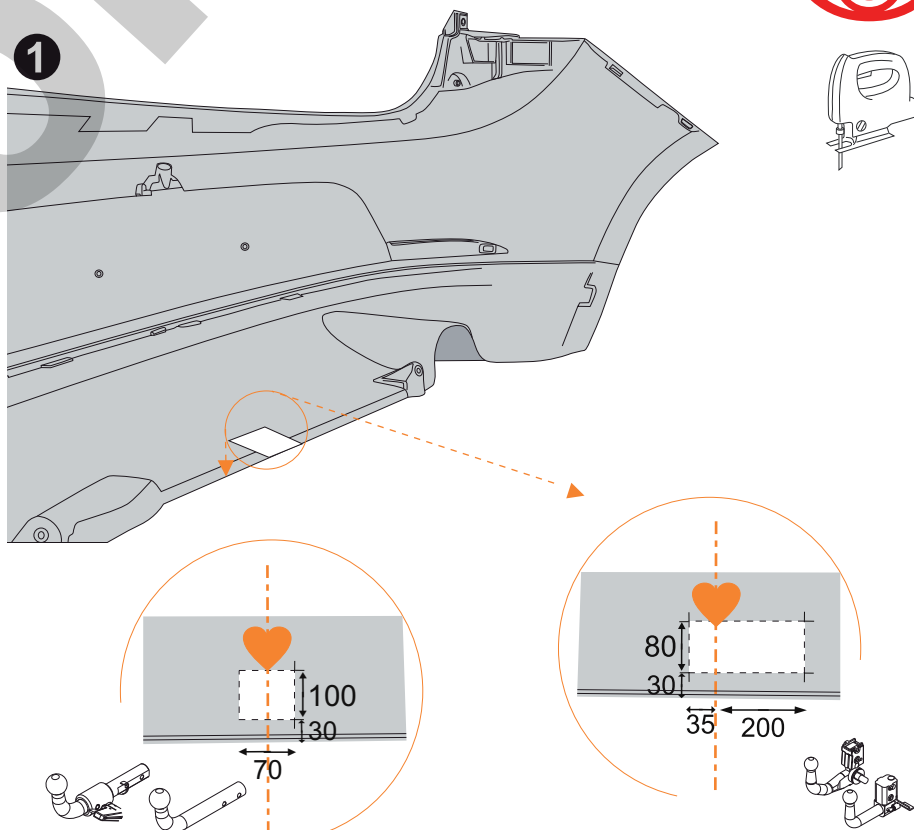

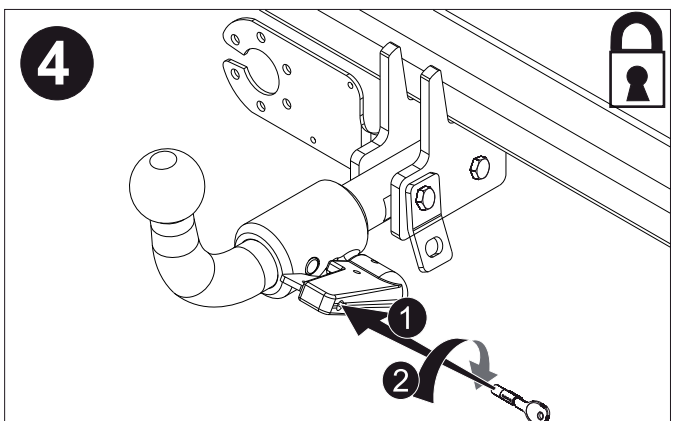
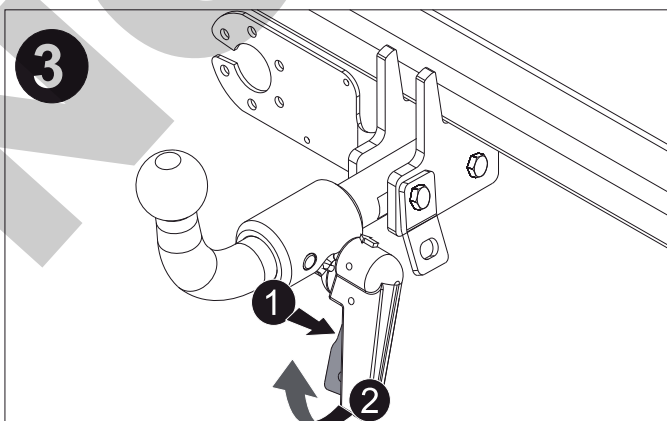
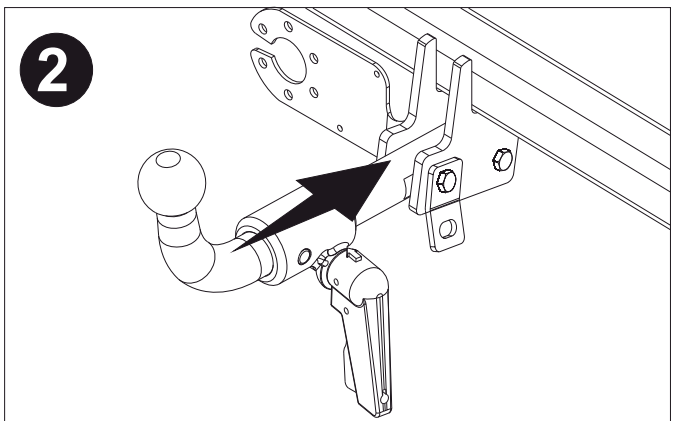
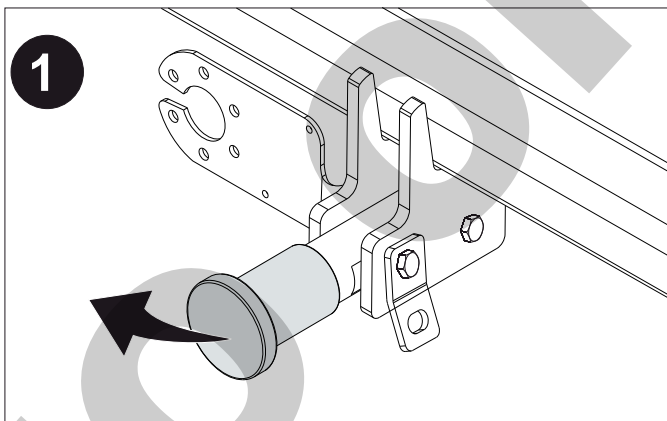
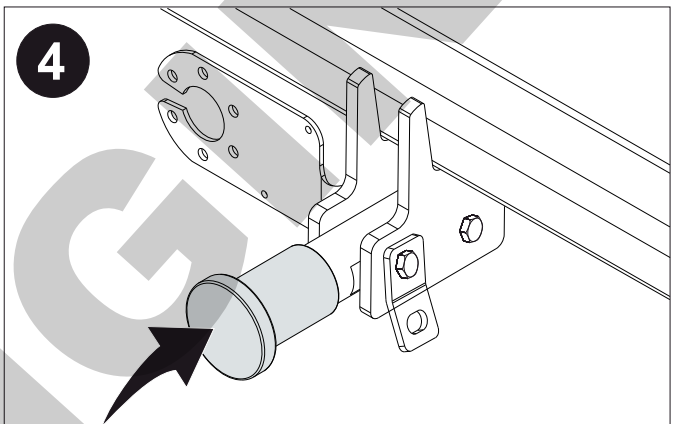
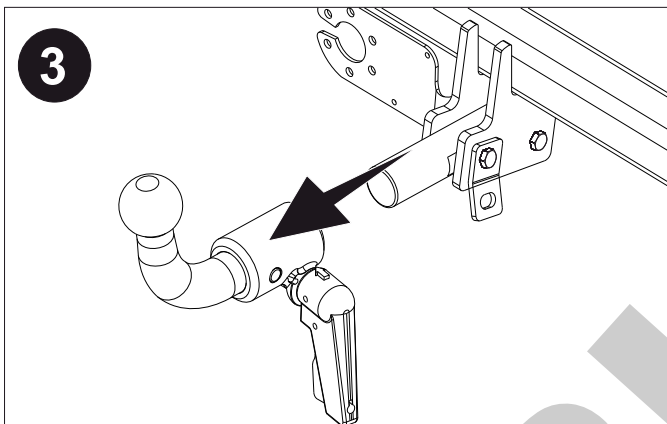
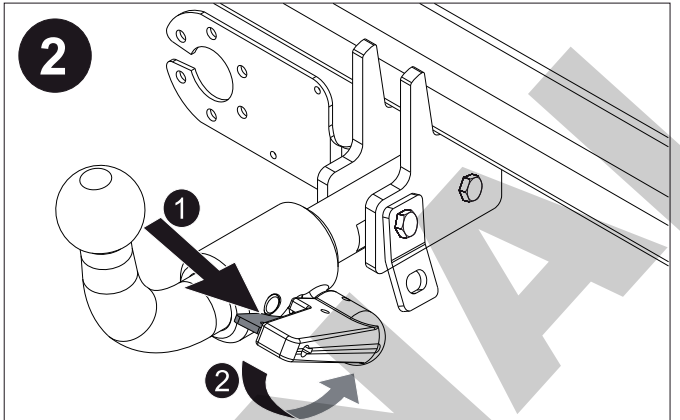
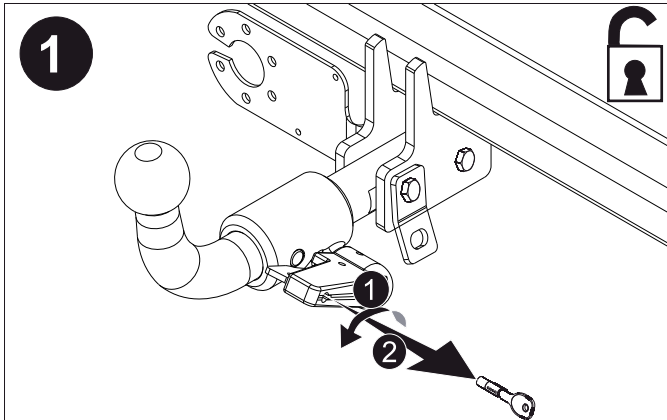

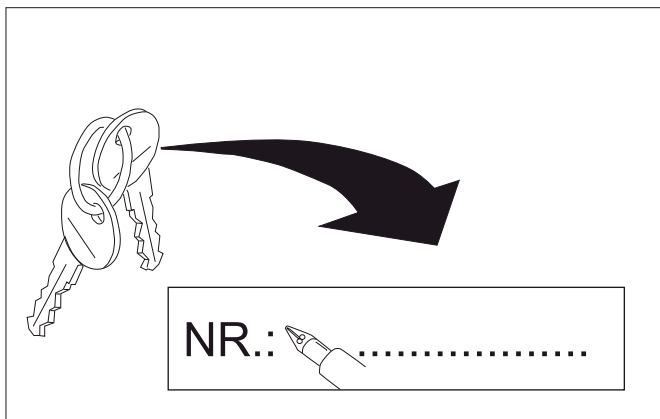
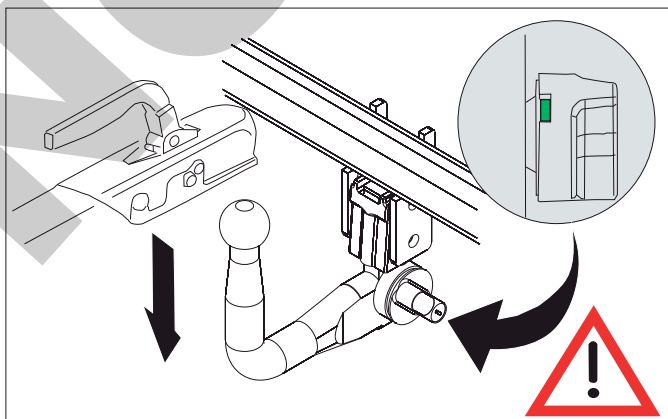
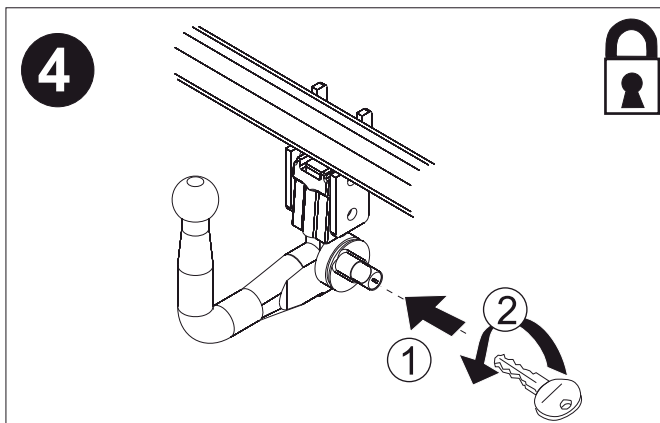
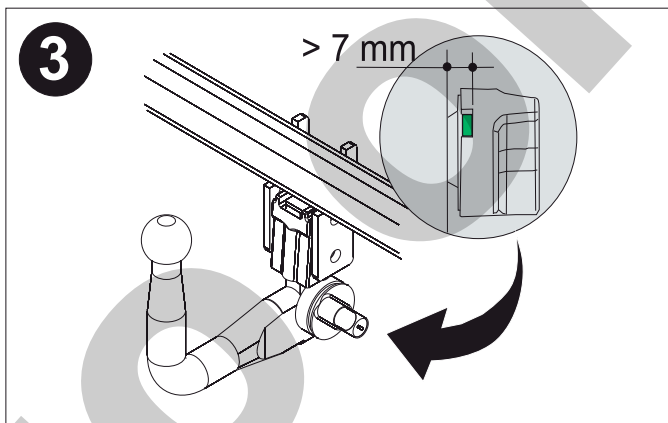
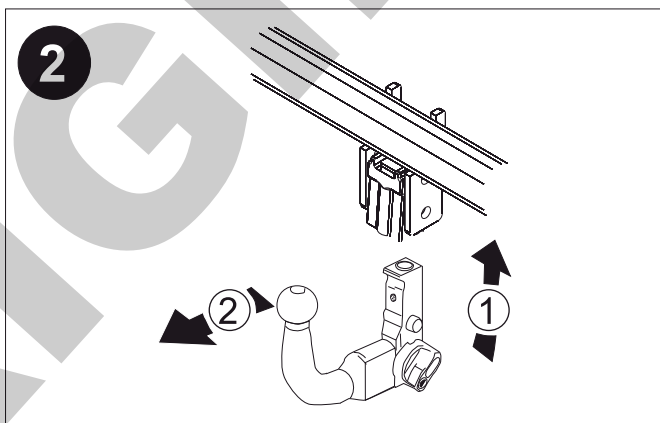
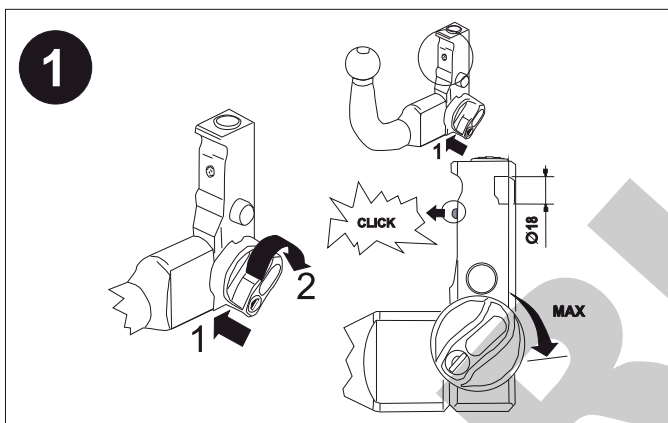
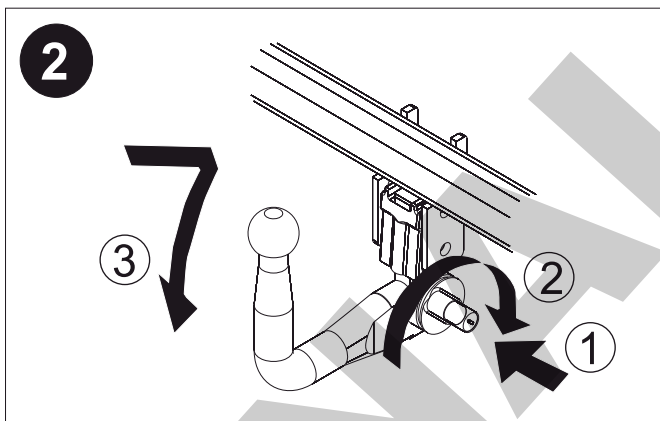
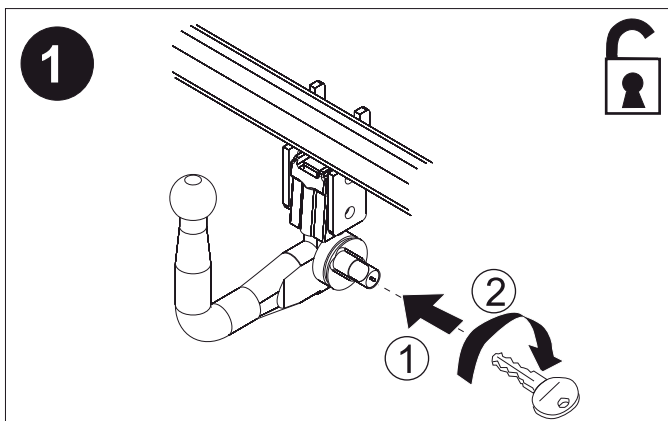

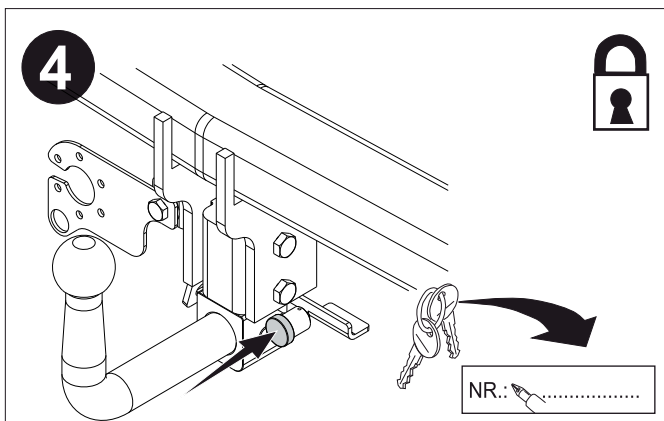
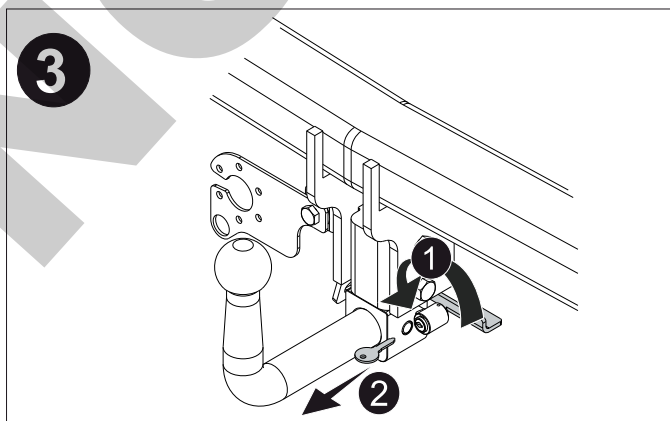
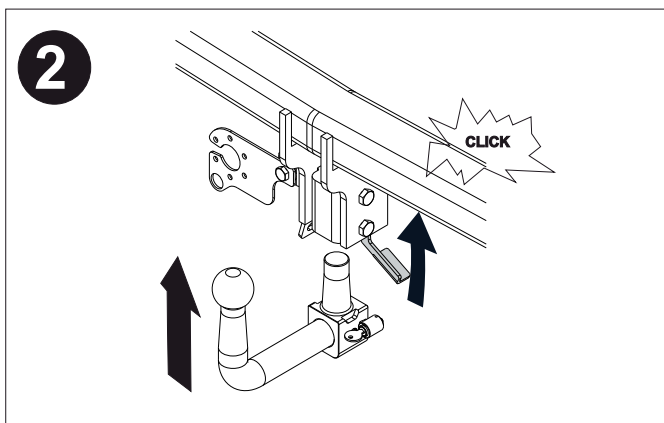
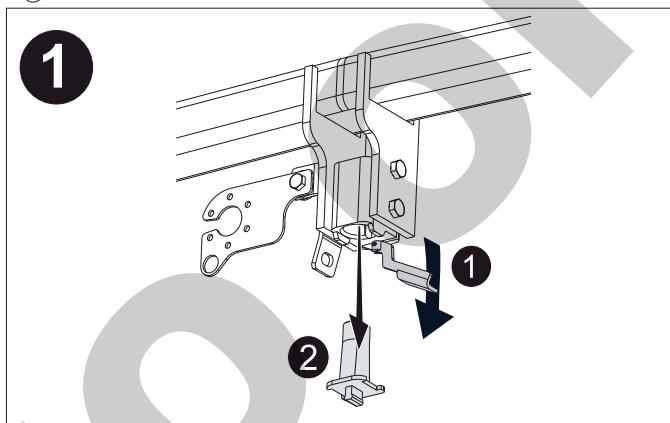
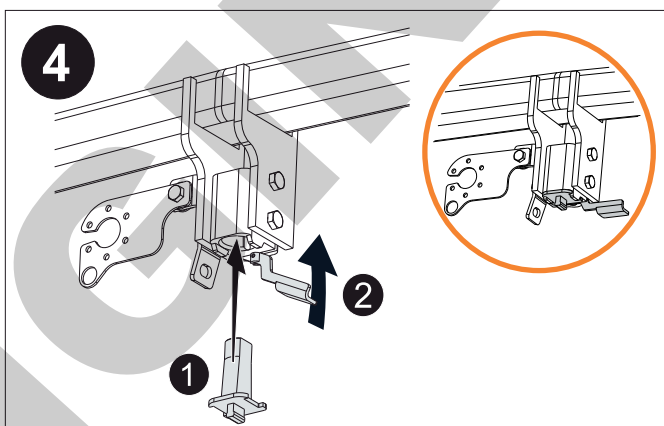
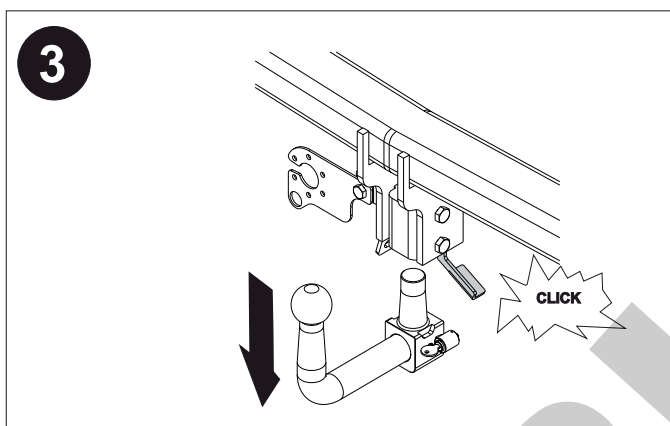
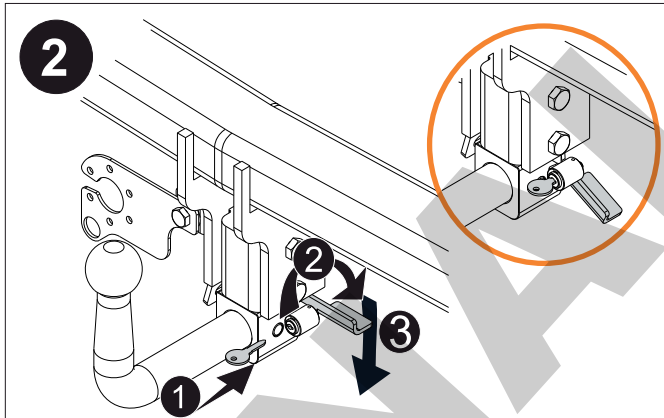
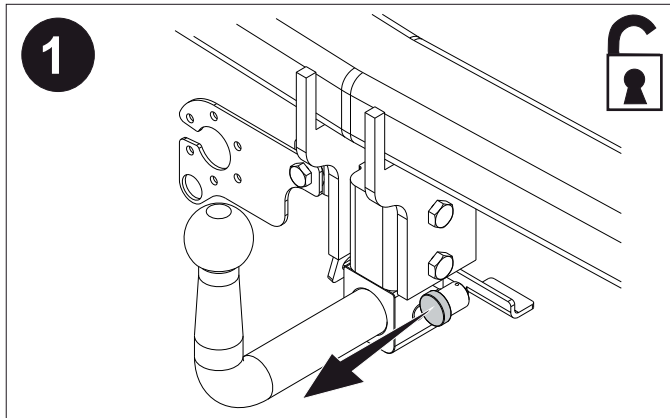

ANEXO III

CERTIFICADO DE TALLER

D. _____, expresamente autorizado por la _____
domiciliada en _____, teléfono _____, dedicada
a la actividad de _____ n° de Registro Industrial _____ y n° de registro
especial _____.

CERTIFICA

Que la mencionada empresa ha realizado la/s Reforma/s y asume la responsabilidad de la ejecución,
sobre el vehículo marca....., tipo.....
variante..... denominación comercial
matrícula y n° de bastidor, de acuerdo con:

- La normativa vigente en materia de reformas de vehículos.
- Las normas del fabricante del vehículo aplicables a la/s reforma/s llevadas a cabo en dicho vehículo.
- El proyecto descriptivo de la/s reforma/s, adjunto al expediente.

OBSERVACIONES: (2)

Tipificada/s con el código de reforma/s.....
Reforma consiste en:

COLOCACION DE ENGANCHE _____

n° de identificación / marca de homologación

Type :

Fecha:

Firma y sello:

Fdo:

(1) En el caso de que la reforma sea efectuada por el fabricante se indicará N/A.

(2) Se debe especificar en este apartado OBSERVACIONES, la identificación de los equipos o sistemas modificados, garantizando que se cumple lo previsto en el artículo 6 del reglamento general de vehículos y, en su caso, en el artículo 5 del R. D. 1457/1986 de 10 de enero, por el que se regula la actividad industrial en talleres de vehículos automóviles, de equipos y sus componentes, modificado por 455/2010 de 16 de abril, por el que se modifica el R. D. 1457/1986 de 10 de enero por el que se regulan la actividad industrial y la prestación.



Valor "D"

D = Pag.1 kN

Valor "S"

S = Pag.1 kg

MMR C/F

Pag.1

Nº de Identificación /
Marca de Homologación

ENGANCHES ARAGON

CLASS:

APPROVAL NUMBER

e 13 00-0000

TYPE: XXX

D-VALUE

D kN

MAX. VERT. LOAD

S kg

Tel: +34 976 45 71 30
www.enganchesaragon.com

E

I

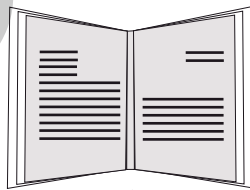

- NL D GB A
- PL RU F TR
- CZ P GR

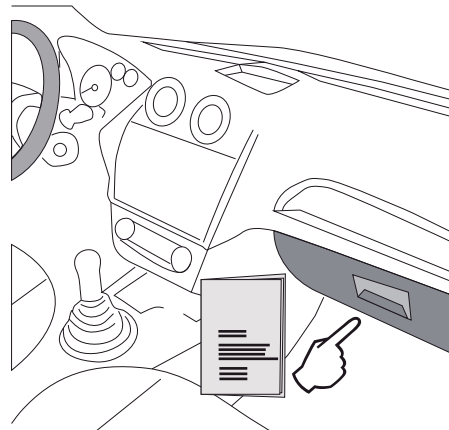
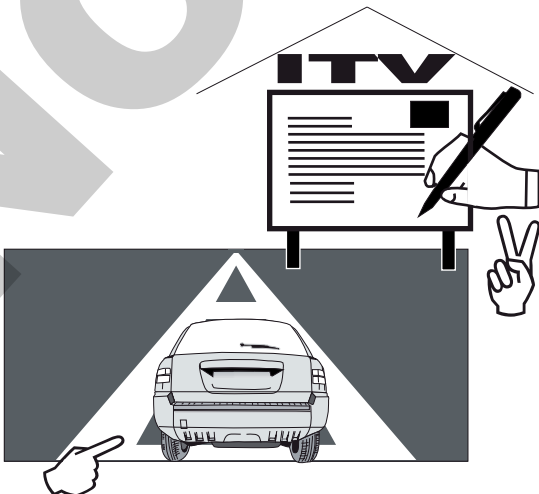

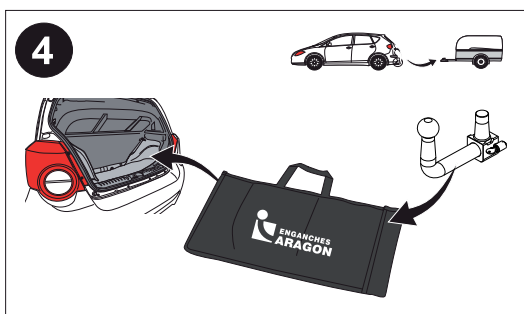
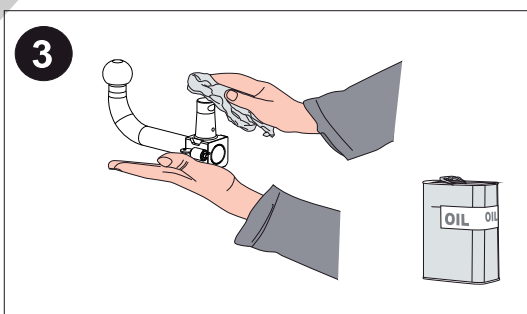
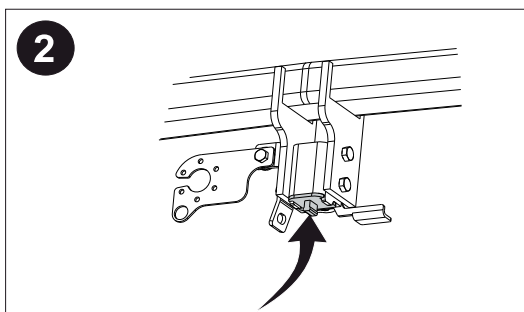
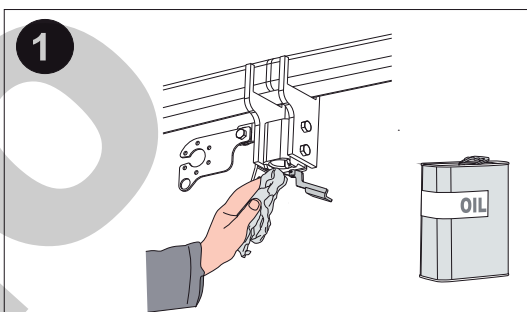
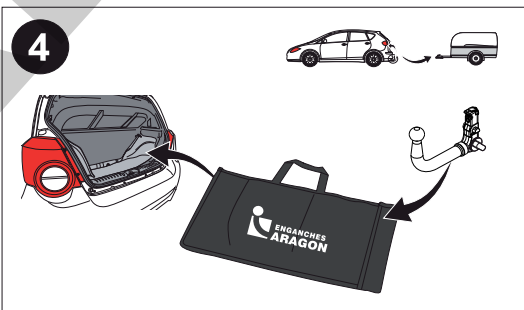
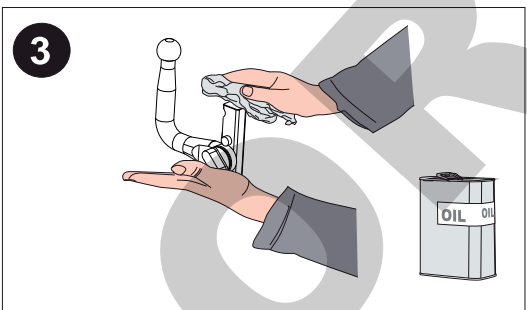
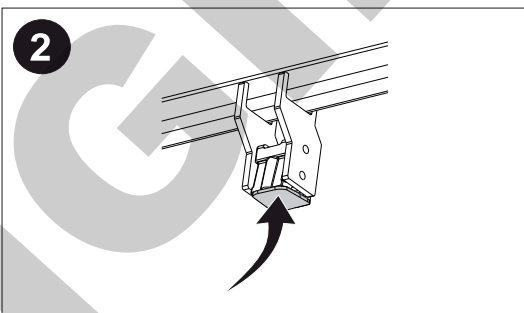
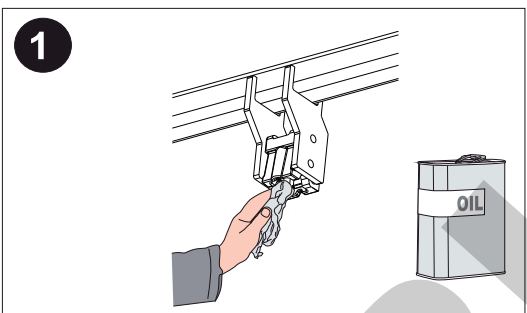
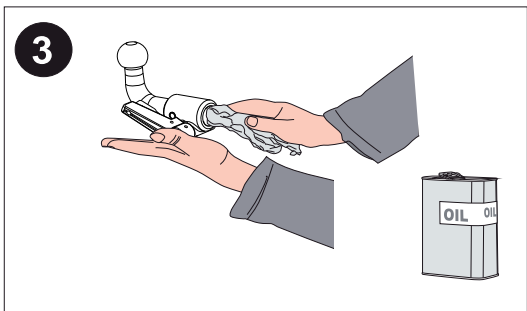
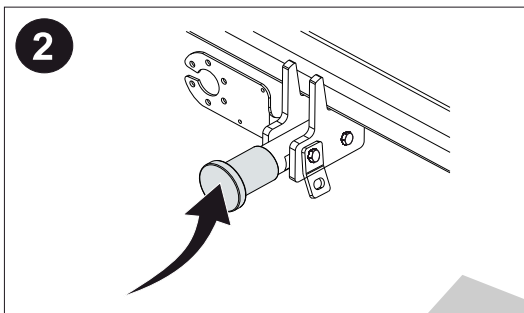
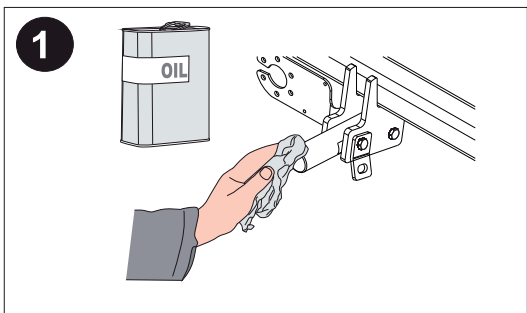

MANTENIMIENTO DE SISTEMAS EXTRAIBLES
DETACHABLE SYSTEMS MAINTENANCE





E

□ Dependiendo de la versión y el año, una parte del paragolpes puede ser necesariamente recortada.

La información proporcionada por nosotros para el recorte del paragolpes es sólo una ayuda no vinculante.

El recorte se sabrá correctamente durante el montaje, con el tamaño requerido.

GB

□ Depending on car's version and year, part of the bumper need to be cut.

Information provided by us for the cutting of bumper is only a non binding help.

The cut will know properly during assembly with the required size.

F

□ Selon la version et l'année du véhicule, une partie du parechoc peut être découpée.

L'information transmise pour la découpe est seulement une aide , à chacun de vérifier la découpe nécessaire.

La découpe se verra correctement durant le montage , aux dimensions requises.

I

□ Dipendendo dalla versione e dell'anno, un pezzo del paraurti può essere tagliato.

L'informazione proporzionata da noi per il paraurti è solo un aiuto non vincolante.

Il taglio si saprà esattamente durante il montaggio col formato necessario.

D

□ Je nach Ausstattungsvariante und Baujahr kann ein Ausschnitt des Stoßfängers zur Nachrüstung erforderlich sein.

Von uns gemachte Angaben zum Ausschnitt des Stoßfängers sind nur eine unverbindliche Hilfestellung.

Der Ausschnitt ist fachgerecht im Zuge der Montage auf die erforderliche Größe vorzunehmen.



TR

Enganches Aragon firması tüm ürünlerine (Çeki Topuzu Sistemleri) teslim tarihinden itibaren iki (2) yıl garanti vermektedir. Bu garanti, Avrupa Birliği tarafından verilen tarifname 1999/44/CE ve 23/2003 kanununa göre sahte ürünlerle değiştirilmesi halinde sınırlandırılmış ve de hasara ve zarara uğrama durumlarında hiçbir şekilde geçerli değildir.

ENGANCHES ARAGON Firması tarafından imal edilen Çeki Sistemleri markasına göre araçlara monte edilebilmektedir.

Çeki Topuzu Sistemlerimiz üzerindeki herhangi bir değişiklik yapmak yasaktır. Bu şartın ihlalinde (e) Avrupa Birliği garantisi ve ürün garantisini geçireliliğini kaybetmektedir.

Araçların modeline ve senesine göre, arka tamponunun bir parçasının kesilme gerekmektedir.

Arka Tamponun kesilmesi için tarafımızdan verilen bilgi sadece bağlayıcı olmayan bir yardımdır.

Tampon kesimi sadece montaj esnasında verilen ölçülerde yerine getirilmelidir.

GR

H Enganches Aragon προσφέρει εγγύηση 2 ετών για τα προϊόντα της, με έναρξη την ημερομηνία παράδοσης των προϊόντων της, σύμφωνα με την οδηγία της Ε.Ε. 1999/44/CE τον νόμο 23/2003. Η υποχρέωση που πηγάζει για την ENGANCHES ARAGON από την εν λόγω εγγύηση περιορίζεται στην αντικατάσταση των ελαττωματικών προϊόντων και σε καμία περίπτωση δεν επεκτείνεται σε άλλες ζημιές ή επακόλουθες βλάβες.

Οι κοσασδόροι που κατασκευάζονται από την ENGANCHES ARAGON, ταιριάζουν στην αναφερόμενη μάρκα αυτοκινήτου για την οποία προορίζονται.

Απαγορεύεται να κάνετε οποιαδήποτε τροποποίηση στους κοσασδόρους μας. Στην περίπτωση που κάτι τέτοιο συμβεί αυτό ακυρώνει την εγγύηση του προϊόντος.

Αναλόγως με τον τύπο και την χρονολογία του αυτοκινήτου, πρέπει να γίνει ένα κόψιμο στον προφυλακτήρα.

Η παρεχόμενη πληροφόρηση για το κόψιμο δεν είναι δεσμευτική και πρέπει να γίνει ακριβώς στην απαιτούμενη διάσταση, κατά την διάρκεια της τοποθέτησης του προφυλακτήρα στο αυτοκίνητο.

P

A firma Enganches Aragon, oferece garantia dos seus produtos por um período de dois anos a partir da data de entrega conforme o disposto na directiva 1999/44/CE e Decreto lei 23/2003. Esta garantia está limitada à substituição de mercadoria defeituosa, não sendo passível de qualquer indemnização por parte do adquirente.

Os engates de reboque fabricados por esta firma são exclusivos e apropriados a cada modelo das diferentes marcas para as quais fabrica.

É expressamente proibida toda e qualquer modificação ou transformação da mercadoria, caso no qual qualquer destas infracções dará lugar à anulação da homologação e garantia dos mesmos.

RU

Производители фаркопов «Энганчес Арагон» предоставляют гарантию на свои изделия сроком на два года с момента доставки, согласно Распоряжению Европейского Союза 1999/44 и Закону 23/2003, при этом замена производится только в случае бракованного товара и не распространяется на причиненные повреждения и неполадки.

Фаркопы, изготовленные на фабрике «Энганчес Арагон», адаптируются к марке автомобиля.

Запрещается изменять или модифицировать любой из наших товаров. Несоблюдение данного требования приведет к прекращению гарантии на товар и к его несоответствию стандартам качества. В зависимости от версии и года выпуска, возможно, потребуется произвести вырез на бампере.

Информация, связанная с вырезом на бампере, предоставляется в качестве вспомогательной и не носит обязательный характер.

Точные размеры выреза станут известны во время монтажа.

Необходимо заделать все места крепления фаркопа на автомобиле, чтобы предотвратить попадание воды.

PL

Enganches Aragon oferuje dwuletnią gwarancję na swoje produkty od daty dostarczenia, zgodnie z europejską dyrektywą 1999/44/CE i prawem 23/2003. Gwarancja obejmuje wyłącznie wymianę wadliwych produktów. Gwarancja nie może być poszerzona o wypłatę odszkodowania czy powstałe szkody.

Hak holowniczy Enganches Aragon odpowiedni dla marki samochodu.

Zabronione jest dokonywanie jakichkolwiek modyfikacji naszych haków holowniczych. Niezastosowanie się spowoduje utratę gwarancji.

CZ

Firma Enganches **Aragon** poskytuje na své výrobky záruka po dobu 2 let od data jejich dodání. Ve smyslu znění evropské směrnice 1999/44/CE a zákona 23/2003 je záruka omezena na výměnu vadných výrobků a v žádném případě se záruka nevztahuje na náhradu vzniklé škody, nebo ublížení.

Tažné zařízení vyrobené u ENGANCHES ARAGON vhodné pro tuto značku vozidla.

Na našich tažných zařízeních je zakázáno provádět jakékoliv úpravy. Nesplnění této podmínky ruší schválení a záruku na výrobek.

Výřezu do nárazníku záleží na verzi a roku výroby vozidla. Informace, které poskytujeme jsou pouze orientační a nezávazné.

Výřez do nárazníku, včetně jeho rozsahu, je znám až během montáže.

Nutnost výřezu do nárazníku záleží na verzi a roku výroby vozidla. Informace, které poskytujeme jsou pouze orientační a nezávazné. Výřez do nárazníku, včetně jeho rozsahu, je znám až během montáže

A

تقدم إنكنشيس أرغون مدة سنتين كضمان على منتجاتها ابتداء من تاريخ التسليم طبقا لما جاء في توجيهات الاتحاد الأوروبي 44/1999 والقانون رقم 23/2003 وتخص حصريا البضاعة التي بها عيوب أو أخطاء. ولا تمنح أبدا في حالات التلف أو الاستخدام الغير الجيد.

صنع المنتج من طرف إنكنشيس أرغون وهو موافق لنوع هذه السيارة .

يمنع منعاً كلياً أي تغيير أو تحويل قد تتعرض لها بضاعتنا. عدم التقيد بذلك يلغي شروط الضمان بالكامل.

ENGANCHES Y REMOLQUES ARAGÓN S.L.



Polígono Industrial Malpica, Calle B, Parcela 77

Tel. 00 34 976 45 71 30 | 00 34 902 45 71 30

Fax 00 34 976 45 71 31

E 50016 Zaragoza (España)

E mail: eng@enganchesaragon.com

www.enganchesaragon.com

