

DB202117

INSTALLATION INSTRUCTIONS

Bradley manufacture high quality towing solutions and supply detailed fitment instructions to users to ensure the correct installation, usage and maintenance of our products. Bradley cannot be held responsible should an accident occur due to the incorrect fitment of our products or due to inappropriate usage or lack of maintenance.

Note: Illustrations show typical mounting arrangement. Actual assembly may differ.

Fasten Frame (Part No.68247) to chassis or towbar using the M16 Grade 8.8 Bolts in conjunction with a washer and M16 Nut as supplied.
Torque to 160 Nm – 200 Nm.

Fig.1:

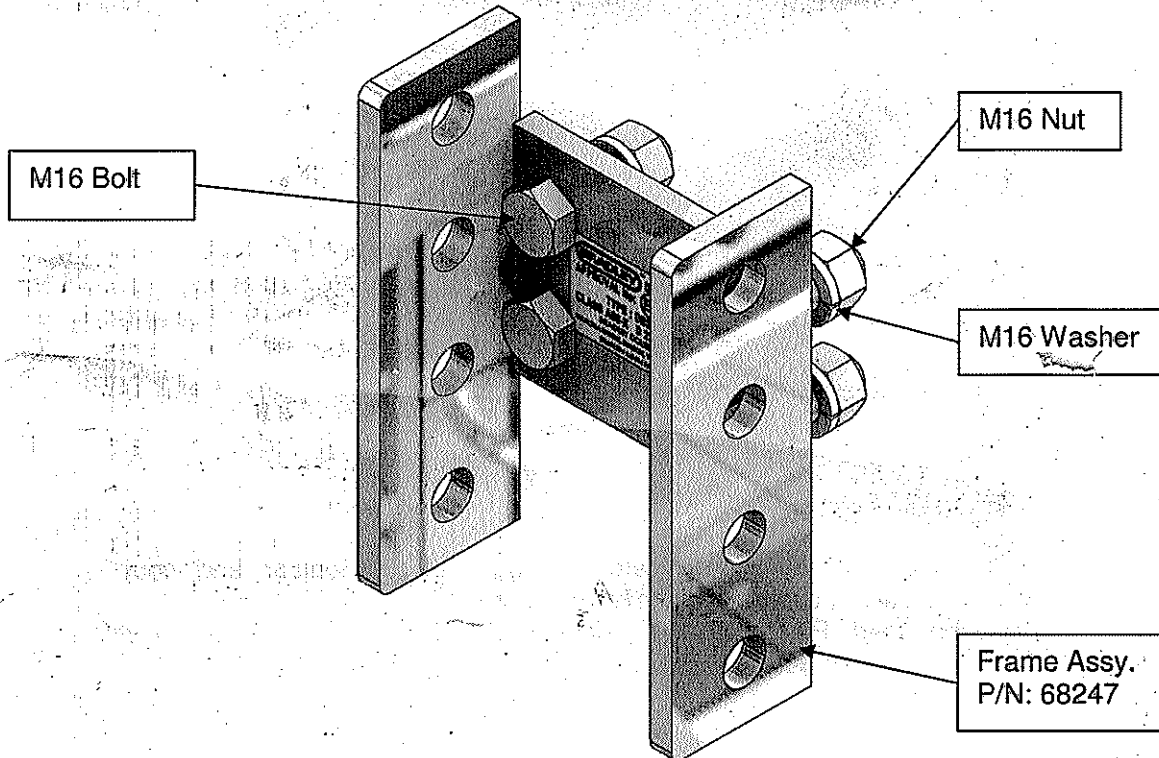

Note: In this configuration the towing capacity is limited to 3500kg.

Bradley Doublelock Ltd, Victoria Works, Bingley, West Yorkshire, BD16 2NH

Tel: +44 (0)1274 560414 / 516760 Fax: +44 (0)1274 551114

www.bradleydoublelock.co.uk

Secure slider (P/N: 68248) to frame using Pin (P/N: 66702) and 'R' - clip (P/N: 102960) as illustrated in Fig. 2. Use two off M16 Bolts, nuts & washers, supplied, to secure your coupling to slider.

Fig. 2:

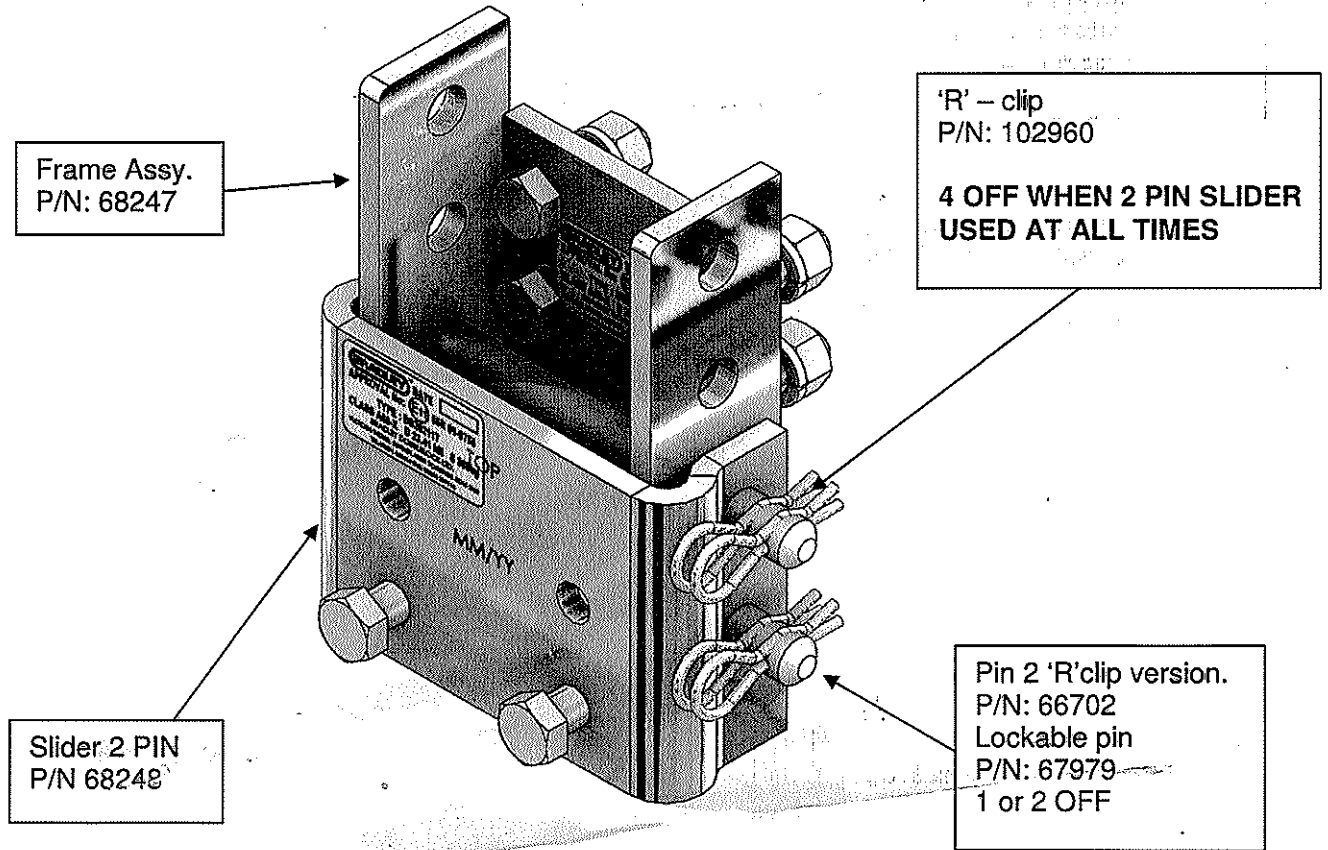

For maximum towing capacity please refer to your vehicle, towbar and coupling manufacturer MGTW data and apply whichever is lower. A stabiliser may be used. Please refer to the manufacturer's fitting instruction when fastening either a coupling device or stabiliser to the slider.

Bradley Doublelock Ltd, Victoria Works, Bingley, West Yorkshire, BD16 2NH

Tel: +44 (0)1274 560414 / 516760 Fax: +44 (0)1274 551114

www.bradleydoublelock.co.uk